

一站式解决舞台灯光和LED屏幕的使用难题

One-Stop Solution To The Use Problems Of Stage Lighting And LED Screens



HELLO LIGHT[®]
STAGE LIGHTING



KALE
FOR AFRICA

公司简介 COMPANY PROFILE

成为客户满意度最高的舞台灯光企业
Become The Highest Customer's Satisfaction Company In Stage Lighting Industry

广州卡乐舞台灯光设备有限公司是一家集自主研发、生产、销售、租赁服务于一体的专业舞台灯光制造商。公司从源头开始,对产品的各个生产环节进行严格的质量控制。公司除了为客户提供优质的产品外,还可以根据客户的需求为客户提供一系列专业的舞台设计建议,以“诚信为本、质量第一、自主创新”作为公司发展的基本原则,始终坚持“高品质”的产品定位,绝不以低质量的产品损害公司和国家的形象,扰乱国内外照明市场进行恶性竞争,公司竭诚欢迎各界同仁和客户光临到世界各地参观指导。

Guangzhou KALE Stage Lighting Equipment Co., Ltd. is a professional stage lighting manufacturer integrating independent research and development, production, sales, and leasing services. The company starts from the source to carry out strict quality control on each production link of the product. In addition to providing customers with high-quality products, the company can also provide customers with a series of professional stage design suggestions based on customer needs, with "integrity-based, quality first, independent innovation" as the basic principles of the company's development, and always adhere to the "High-quality" product positioning, will never damage the image of the company and the country with low-quality products, disrupt domestic and international lighting markets for vicious competition, the company sincerely welcomes colleagues and customers from all over the world to visit and guide.

企业发展历程

ENTERPRISE DEVELOPMENT HISTORY



工程案例 PROJECT

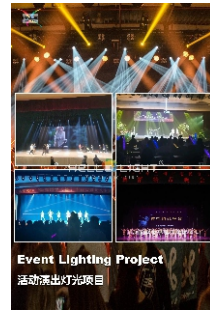
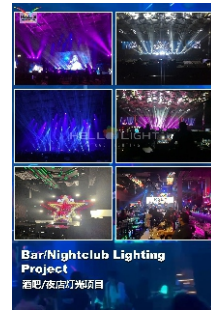
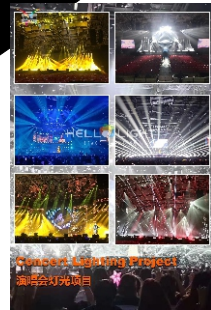
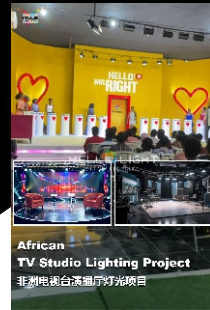

商务合作 BUSINESS



资质证书 CERTIFICATIONS



LED 产品生产线和设备

LED Production Line & Equipment



Factory environment

Focus on independent Research & Development

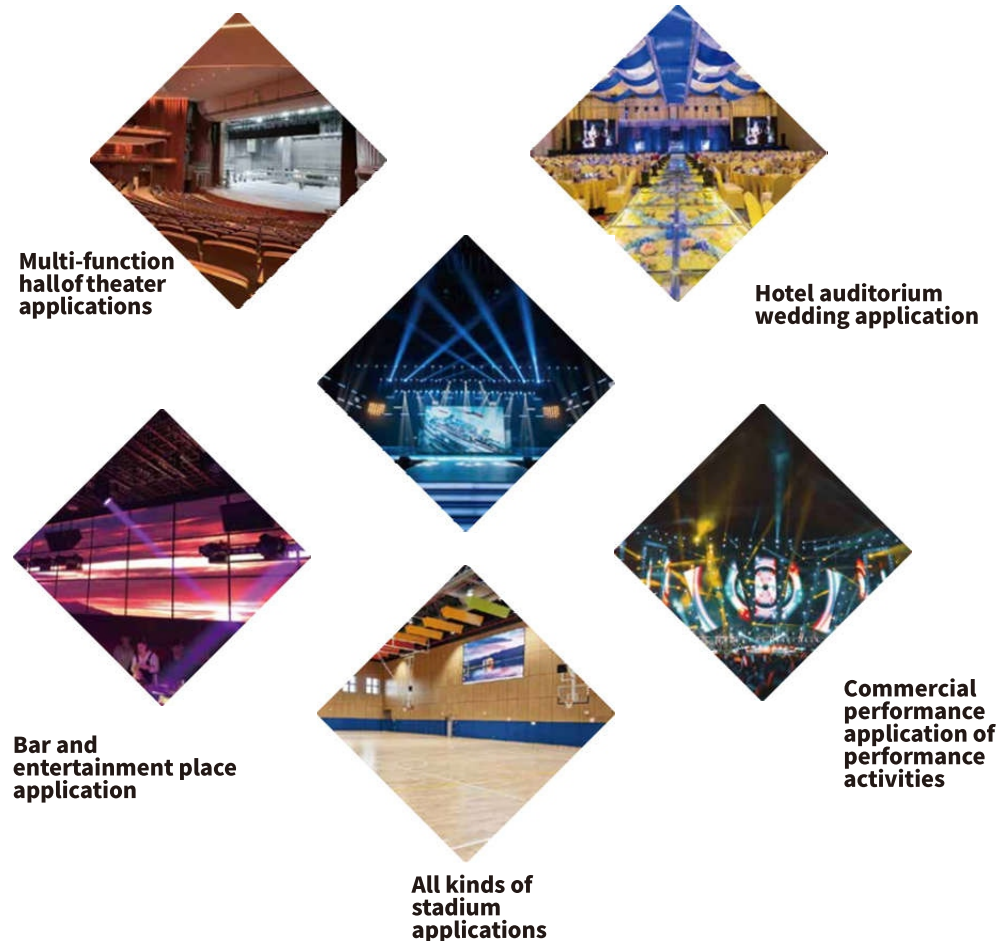

Multi-function hall of theater applications

Hotel auditorium wedding application

Bar and entertainment place application

Commercial performance application of performance activities

All kinds of stadium applications

- Make plans for the next three years
- Give a high advantage in product research and upgrade
- Explore Self-design and patented products

KL-BSWF1000L

1000W LED 光束/聚光/染色/切割电脑灯 1000W LED B/S/W/F Moving Head Light

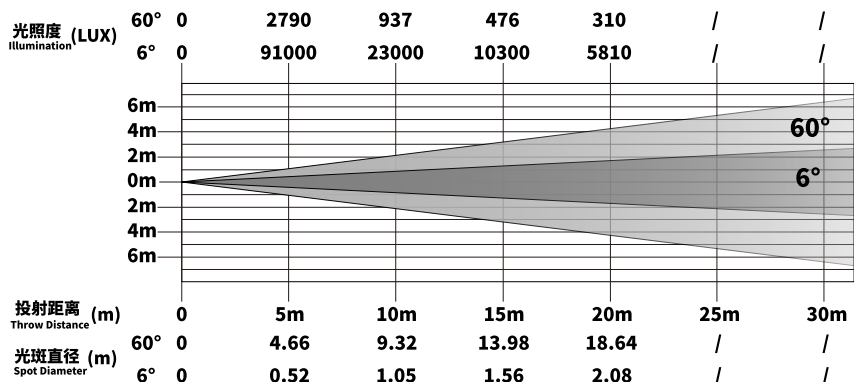

Technical Specifications

Light Source
Light source: 1000W LED module
LED life: 20,000 hours

Optical System
Color temperature: 6500K
Diameter: 150mm
Color rendering index: standard mode Ra>75, high display mode Ra>90
Luminous flux: 32000LM

Power Supply
Input voltage: AC100-240V, 50/60Hz
Rated power: 1050W

Functional Effect
Fixed color: 6 colors + white light
Color mixing system: Independent CMY color mixing system
Color temperature adjustment: independent CTO 2800K-6500K linear adjustment
Prism disk: rotating 3 prisms + 6 rows of mirrors"
Effect panel: dynamic effects such as stunning simulated dynamic flames, gurgling water, etc.
Fixed gobos: 11 plug-in fixed gobos with an outer diameter of 25.4mm+white circle
Rotating gobo: 7 gobos (pluggable) with an outer diameter of 26.9mm, an effective diameter of 16.5mm, and a thickness of 11mm"
Cutting system: 4 independent cutting pieces, each piece can be individually closed, and can be rotated 90°
Atomization system: 0~100% linear atomization
Aperture system: 6%~100% smooth adjustment
Zoom system: 5.5°~60° linear zoom
Dimming system: 0-100% linear adjustment
Strobe system: the highest frequency can reach 25Hz, and random strobe and pulse strobe horizontal scanning can be selected

Controls And Procedures
Signal interface: optional three-core Kayimo/five-pin Kayimo seat
Control mode: DMX512, RDM, self-propelled, master-slave, voice control
Channel mode: 36 international standard DMX512 channels
Display system: 2.7-inch touch LCD display, Chinese and English display, 180-degree rotation

Pan&Tilt Axis
Pan rotation angle: 540° (16 bit precision scanning)
Tilt rotation angle: 270° (16 bit precision scanning)
Pan/Tilt axis position correction: five-phase motor with magnetic encoding positioning function

Lighting Specifications
Protection class: Ip20
Working environment: 0-45C
Height: 800mm
Width: 510mm
Depth: 345mm
Net weight: 43KG
Gross weight: 51.5KG
Shell material: flame retardant, high temperature resistant, folding integrated lamp hook

技术参数

光源
光源:1000W LED 模组
LED寿命:20,000小时

光学系统
色温:6500K
口径:150mm
显色指数:标准模式Ra>75.高显模式Ra>90
光通量:32000LM

电源
输入电压:AC100-240V,50/60Hz
额定功率:1050W

功能效果
固定颜色:6种颜色+白光
混色系统:独立的CMY混色系统
色温调节:独立的CTO 2800K-6500K线性调节
棱镜盘:旋转3棱镜+6排镜"
效果盘:超炫模拟动感窜动的火焰,潺潺流水等动态效果
固定图案:11个插拔式的固定图案片外径25.4mm+白圈
旋转图案:7个图案片(可插拔)外径26.9mm,有效直径16,5mm,厚度11mm"
切割系统:4个独立切割片,每片可单独闭光,可旋转90°
雾化系统:0~100%线性雾化
光圈系统:6%~100%顺滑调整
缩放系统:5.5°~60°线性变焦
调光系统:0-100%线性调节
频闪系统:频率最高可以达到25Hz,并可选择随机频闪及脉冲频闪水平扫描

控制与程序
信号接口:三芯卡依摩/五芯卡依座选配
控制方式:DMX512、RDM、自走、主从、声控
通道模式:36个国际标准DMX512通道
显示系统:2.7英寸触摸液晶显示屏,中英文显示,180度旋转

X/Y轴
X轴转动角度:540° (16 bit精度扫描)
Y轴转动角度:270° (16 bit精度扫描)
X/Y轴位置校正:采用五相电机带磁编码定位功能

灯具规格
防护等级:Ip20
工作环境:0-45C
高度:800毫米
宽度:510毫米
深度:345毫米
净重:43KG
毛重:51.5KG
外壳材质:阻燃,耐高温,折叠一体式灯钩

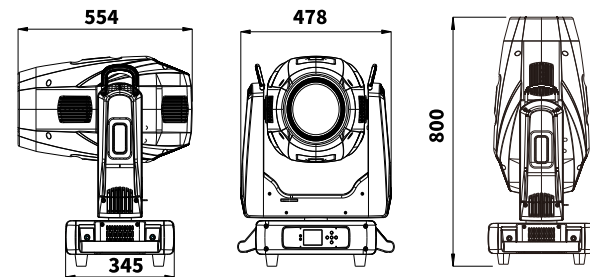

KL-BSWF700L

700W LED 光束/聚光/染色/切割电脑灯 700W LED B/S/W/F Moving Head Light



光照度 (LUX) Illumination	50°	0	2400	600	266	150	96	66
	5°	0	98000	24500	10888	6125	3920	2722
投射距离 (m) Throw Distance	50°	0	5m	10m	15m	20m	25m	30m
	5°	0	4.65	9.30	13.95	18.60	23.25	27.60
光斑直径 (m) Spot Diameter	50°	0	0.44	0.88	1.32	1.76	2.2	2.64
	5°	0	0.44	0.88	1.32	1.76	2.2	2.64

Technical Specifications

Light Source
Light source: 700W LED module
LED life: 20,000 hours

Optical System
Color temperature: 6500K
Diameter: 150mm
Color rendering index: standard mode Ra>75, high display mode Ra>90
Luminous flux: 32000LM

Power Supply
Input voltage: AC100-240V, 50/60Hz
Rated power: 1050W

Functional Effect
Fixed color: 6 colors + white light
Color mixing system: Independent CMY color mixing system
Color temperature adjustment: independent CTO 2800K-6500K linear adjustment
Prism disk: rotating 3 prisms + 6 rows of mirrors"
Effect panel: dynamic effects such as stunning simulated dynamic flames, gurgling water, etc.
Fixed gobos: 11 plug-in fixed gobos with an outer diameter of 25.4mm+white circle
Rotating gobo: 7 gobos (pluggable) with an outer diameter of 26.9mm, an effective diameter of 16.5mm, and a thickness of 11mm"
Cutting system: 4 independent cutting pieces, each piece can be individually closed, and can be rotated 90°
Atomization system: 0~100% linear atomization
Aperture system: 6%~100% smooth adjustment
Zoom system: 5.5°~60° linear zoom
Dimming system: 0-100% linear adjustment
Strobe system: the highest frequency can reach 25Hz, and random strobe and pulse strobe horizontal scanning can be selected

Controls And Procedures
Signal interface: optional three-core Kayimo/five-pin Kayimo seat
Control mode: DMX512, RDM, self-propelled, master-slave, voice control
Channel mode: 36 international standard DMX512 channels
Display system: 2.7-inch touch LCD display, Chinese and English display, 180-degree rotation

Pan&Tilt Axis
Pan rotation angle: 540° (16 bit precision scanning)
Tilt rotation angle: 270° (16 bit precision scanning)
Pan/Tilt axis position correction: five-phase motor with magnetic encoding positioning function

Lighting Specifications
Protection class: Ip20
Working environment: 0-45C
Height: 800mm
Width: 510mm
Depth: 345mm
Net weight: 43KG
Gross weight: 51.5KG
Shell material: flame retardant, high temperature resistant, folding integrated lamp hook

技术参数

光源
光源:700W LED 模组
LED寿命:20,000小时

光学系统
色温:6500K
口径:150mm
显色指数:标准模式Ra>75.高显模式Ra>90
光通量:32000LM

电源
输入电压:AC100-240V,50/60Hz
额定功率:1050W

功能效果
固定颜色:6种颜色+白光
混色系统:独立的CMY混色系统
色温调节:独立的CTO 2800K-6500K线性调节
棱镜盘:旋转3棱镜+6排镜"
效果盘:超炫模拟动感喷动的火焰,潺潺流水等动态效果
固定图案:11个插接式的固定图案片外径25.4mm+白圈
旋转图案:7个图案片(可插接)外径26.9mm,有效直径16.5mm,厚度11mm"
切割系统:4个独立切割片,每片可单独闭光,可旋转90°
雾化系统:0~100%线性雾化
光圈系统:6%~100%顺滑调整
缩放系统:5.5°~60°线性变焦
调光系统:0~100%线性调节
频闪系统:频率最高可以达到25Hz,并可选择随机频闪及脉冲频闪水平扫描

控制与程序
信号接口:三芯卡依摩/五芯卡依座选配
•控制方式:DMX512、RDM、自走、主从、声控
通道模式:36个国际标准DMX512通道
显示系统:2.7英寸触摸液晶显示屏,中英文显示,180度旋转

X/Y轴
X轴转动角度: 540° (16 bit精度扫描)
Y轴转动角度: 270° (16 bit精度扫描)
X/Y轴位置校正:采用五相电机带磁编码定位功能

灯具规格
防护等级: Ip20
工作环境: 0-45C
高度: 800毫米
宽度: 510毫米
深度: 345毫米
净重: 43KG
毛重: 51.5KG
外壳材质:阻燃,耐高温,折叠一体式灯钩

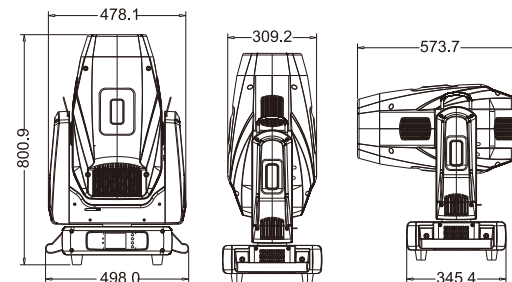

KL-BSWF600L

600W LED 光束/聚光/染色/切割电脑灯 600W LED B/S/W/F Moving Head Light



光照度 (LUX) Illumination	Distance (m)						
	0	5m	10m	15m	20m	25m	30m
50°	0	2400	600	266	150	96	66
5°	0	98000	24500	10888	6125	3920	2722
投射距离 (m) Throw Distance	0	5m	10m	15m	20m	25m	30m
光斑直径 (m) Spot Diameter	50°	4.65	9.30	13.95	18.60	23.25	27.60
	5°	0.44	0.88	1.32	1.76	2.2	2.64

Technical Specifications

Light Source
Light source: 600W LED module
LED life: 20,000 hours

Optical System
Color temperature: 6800K
Caliber: 138MM
Color rendering index: standard mode Ra>75 high display mode Ra>90
Luminous flux: 24000LM

Power Supply
Input voltage: AC100-240V, 50/60Hz
Rated power: 900W

Functional Effect
Fixed color: 6 colors + white light
Color mixing system: Independent CMY color mixing system
Color temperature adjustment: Independent CTO2500-7000K
Linear adjustment Prism disk: 3 prisms
Effect plate: dynamic effects such as stunning simulated dynamic flames, gurgling water, etc.
Fixed pattern: 7 metal fixed pattern pieces + white circle
Rotating gobo: 7 gobos (pluggable), outer diameter 22.9, effective diameter 16mm, thickness 1.1mm.
Cutting system: 4 independent cutting pieces, each piece can be closed separately, and can be rotated 90°
Atomizationsystem: 0~100% linear atomization
Aperture system: 5%~100% smooth adjustment
Zoom system: 4.5°~50° linear zoom
Dimming system: 0-100% linear adjustment
Strobe system: the highest frequency can reach 25Hz, and random strobe and pulse strobe horizontal scanning can be selected

Controls and Procedures
Signal interface: optional three-core card base/five-pin card base
Control mode: DMX512, RDM, self-propelled, master-slave, voice control
Channel mode: 36 international standard DMX512 channels
Display system: 2.7-inch touch LCD display, Chinese and English display, 180-degree rotation.

Pan&Tilt Axis
Pan rotation angle: 540° (16-bit precision scanning)
Tilt rotation angle: 270° (16-bit precision scanning)
Pan&Tilt axis position correction: five-phase motor with magnetic encoding positioning function

Lighting Specifications
Protection class: Ip20
Working environment: 0-45°C
Height: 770 mm
Width: 424mm
Depth: 286 mm
Net weight: 35KG
Gross weight: 41KG

技术参数

光源
光源: 600W LED模组
LED寿命: 20,000小时

光学系统
色温: 6800K
口径: 138MM
显色指数: 标准模式Ra>75 高显模式Ra>90
光通量: 24000LM

电源
输入电压: AC100-240V, 50/60Hz
额定功率: 900W

功能效果
固定颜色: 6色+白光
混色系统: 独立CMY混色系统
色温调节: 独立CTO2500-7000K
线性调节棱镜盘: 3棱镜
效果板: 令人惊叹的模拟动态火焰、潺潺流水等动态效果。
固定图案: 7个金属固定图案片+白圈
旋转图案片: 7个图案片(可插拔), 外径22.9, 有效直径16mm, 厚度1.1mm。
切割系统: 4个独立切割片, 每片可单独闭合, 并可旋转90°
雾化系统: 0~100%线性雾化
光圈系统: 5%~100%平滑调节
变焦系统: 4.5°~50°线性变焦
调光系统: 0-100%线性调节
频闪系统: 最高频率可达25Hz, 可选择随机频闪和脉冲频闪水平扫描

控制措施和程序
信号接口: 可选三芯卡座/五针卡座
控制模式: DMX512、RDM、自走、主从、声控
通道模式: 36个国际标准DMX512通道
显示系统: 2.7英寸触摸液晶显示屏, 中英文显示, 180度旋转。

X/Y轴
X轴旋转角度: 540° (16位精度扫描)
Y轴旋转角度: 270° (16位精度扫描)
X/Y轴位置校正: 五相电机, 带磁编码定位功能

灯具规格
防护等级: IP20
工作环境: 0-45°C
高度: 770毫米
宽度: 424毫米
深度: 286毫米
净重: 35KG
毛重: 41KG

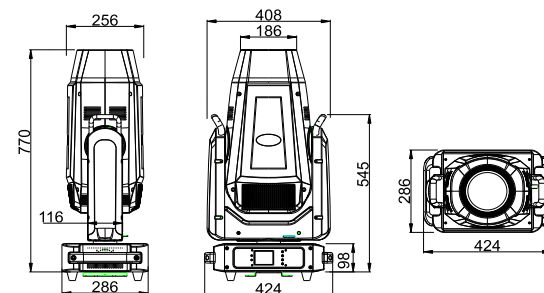

KL-BSW400L

400W LED 光束/聚光/染色电脑灯

400W LED Beam/Spot/Wash Moving Head Light

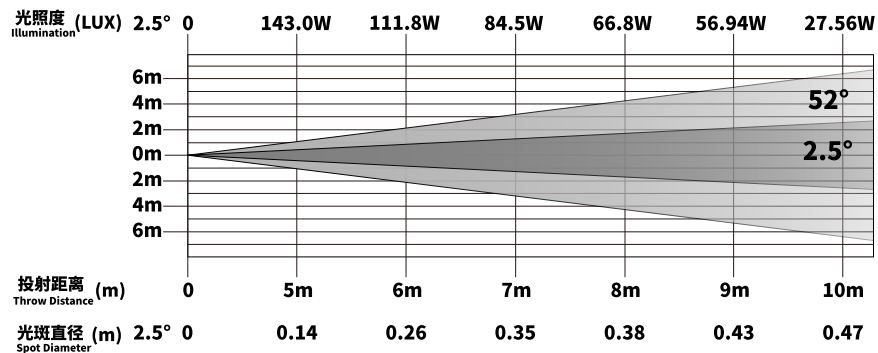

Technical Specifications

Light Source
Light source: 400W LED module
Light source life: 20,000 hours

Optical System
Color rendering index: Ra>85
Lens: high-precision optical lens
Color temperature: 7500K

Power Supply
Input voltage: AC100-240V, 50/60Hz
Rated power: 550W

Functional Effect
Fixed color: 8 colors + white light
Color mixing system: Independent CMY color mixing system
Color temperature adjustment: independent CTO 2700-6500K linear adjustment
Prism disk: rotating 8 prisms + 5 rows of mirrors
Fixed pattern: 10 fixed pattern pieces + 2 white circles
Rotating gobo: 7 rotating gobos (pluggable) outer diameter 22.9mm, effective diameter 11mm+white circle
Atomization system: mild atomization sheet
Zoom system: 2.5°~43° linear focus
Dimming system: 0-100% linear adjustment
Strobe system: fast strobe, pulse strobe

Controls and Procedures
Control mode: DMX512, RDM
Channel mode: 23 international standard DMX512 channels
Display system: 2.5-inch touch LCD display, Chinese and English display, 180-degree rotation

Pan&Tilt Axis
Pan rotation angle: 540°
Tilt rotation angle: 270°
Pan&Tilt axis position correction

Lighting Specifications
Height: 640mm
Width: 380mm
Depth: 275mm
Net weight: 22.5KG
Protection class: Ip20
Working environment: 0-45°C

技术参数

光源
光源: 400W LED模组
光源寿命: 20,000小时

光学系统
显色指数: Ra>85
镜头: 高精度光学镜头
色温: 7500K

电源
输入电压: AC100-240V, 50/60Hz
额定功率: 550W

功能效果
固定颜色: 8色+白光
混色系统: 独立CMY混色系统
色温调节: 独立CTO 2700-6500K线性调节
棱镜盘: 旋转8棱镜+5排镜子
固定图案: 10个固定图案片+2个白圈
旋转图案片: 7个旋转图案片(可插拔)外径22.9mm, 有效直径11mm+白圈
雾化系统: 温和雾化片
变焦系统: 2.5°~43°线性对焦
调光系统: 0-100%线性调节
频闪系统: 快速频闪、脉冲频闪

控制措施和程序
控制模式: DMX512、RDM
通道模式: 23个国际标准DMX512通道
显示系统: 2.5英寸触摸液晶显示屏, 中英文显示, 180度旋转

X/Y轴
X轴旋转角度: 540°
Y轴旋转角度: 270°
X/Y轴位置校正

灯具规格
高度: 640毫米
宽度: 380毫米
深度: 275毫米
净重: 22.5KG
防护等级: IP20
工作环境: 0-45°C

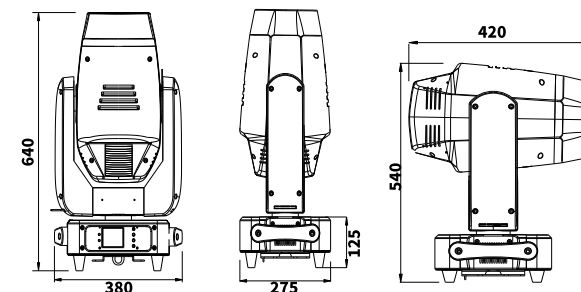

KL-BSW350L

350W LED 光束/聚光/染色电脑灯

350W LED Beam/Spot/Wash Moving Head Light



光照度 (LUX) Illumination	35°	0	9000	4000	/	1500	/	1000
	8°	0	110000	59000	/	25000	/	14000
	6m							
	4m							
	2m							
	0m							
	2m							
	4m							
	6m							
投射距离 (m) Throw Distance	0	2m	3m	4m	5m	6m	7m	
光斑直径 (m) Spot Diameter	8°	0	0.28	0.40	/	0.67	/	0.90
	35°	0	1.26	1.87	/	3.08	/	4.18

Technical Specifications

Light Source
Light Source: 350W High Output White LED
Life expectancy: 50,000 hours lifespan and low power consumption

Optical System
Lens diameter: 180mm
High light output, 25000LUX@5M at White light zoom-in, 1500LUX@5M at White light zoom out

Control & Program
Focus: Zoom angle 8°~35°, focus function, High precision optical lens, electronic linear control
Double prism: 8-16 prism bidirectional variable speed rotation
Linear Dimmer: Mechanical dimmer 0-100%
Prism: 8-facet Prism, bi-directional rotatable at variable speeds
Frost effect
Strobe: High-speed strobe effect with 0.3-25 flashes per second
Control mode: 16/18 DMX Channels USITT DMX-512
Channel mode: DMX 512, master-slave and sound activated controllable or auto operation
Display Panel: Colorful LCD display

PAN & TILT
Pan movement: 540°
Tilt movement: 270°
Automatic Pan/Tilt position correction

Gobos Wheel
1 Rotation Gobo Wheel: 7 gobos + white, wheel rotation and shake, The gobo plate is Removable, it is more convenient to change the Gobo
1 Static Gobo Wheel: 8 gobos + white, wheel rotation and shake

Color Wheel
Color Wheel: 7 colors + white, color fine-tuning, rotation with variable direction and speed, with a rainbow effect.

Electrical & Connectors
Power supply with electronic auto-ranging
Input voltage: AC90-260V 50/60Hz
Power consumption: 450W

Lighting Specification
Height: 590 mm
Width: 312 mm
Depth: 222 mm
Weight: 16kg

技术参数

光源
光源: 350W 高输出白光 LED
预期寿命: 50,000小时寿命和低功耗消耗

光学系统
镜头直径: 180mm
高光输出, 白光放大时25000LUX@5M, 白光缩小时1500LUX@5M

控制与程序
调焦: 变焦角度8°~35°, 调焦功能, 高精度光学镜头, 电子线性控制
双透镜: 8-16透镜双向变速旋转
线性调光器: 机械调光器0-100%
棱镜: 8面棱镜, 双向变速旋转
霜冻效果
频闪: 高速频闪效果, 每秒闪烁0.3-25次
控制模式: 16/18 DMX 通道 USITT DMX-512
通道模式: DMX 512、主从、声控可控或自动操作
显示面板: 彩色液晶显示屏

X/Y轴
X轴运动: 540°
Y轴运动: 270°
X/Y轴自动平移/倾斜位置校正

图案轮
1个旋转图案轮: 7个图案+白光, 轮旋转摇一摇, 图案板是可拆卸的, 它更方便更换图案片
1个静态图案轮: 8个图案片+白光, 轮旋转和摇

色轮
色轮: 7种颜色+白色, 颜色微调, 旋转方向和速度可变, 具有彩虹效果。

电气与连接器
带电子自动量程的电源
输入电压: AC90-260V 50/60Hz
功耗: 450W

灯具规格
高度: 590毫米
宽度: 312毫米
深度: 222毫米
重量: 16公斤

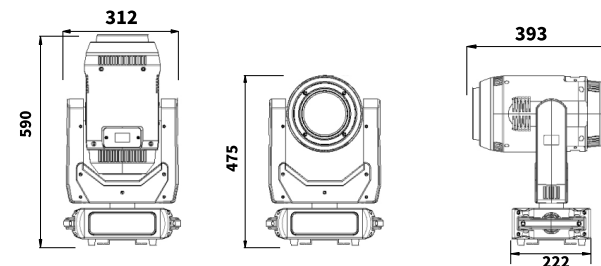

KL-BSW250L

250W LED 光束/聚光/染色电脑灯

250W LED Beam/Spot/Wash Moving Head Light

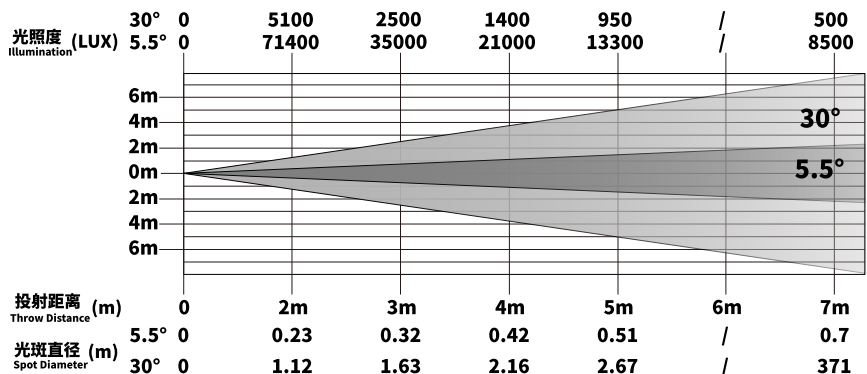
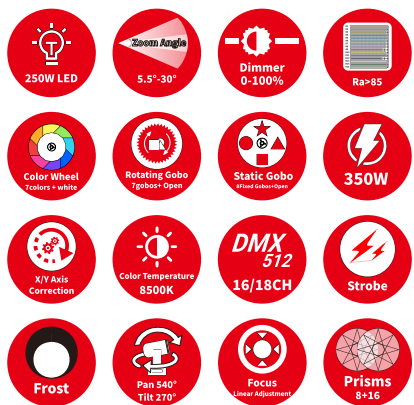

Technical Specifications

Light Source
250W High Output White LED
50,000 hours lifespan and low power consumption

Optical System
Zoom angle 5.5°~30°, focus function
High light output, 13300LUX@5M at White light zoom-in, 950LUX@5M at White light zoom out

Controls And Procedures
Color Wheel: 7 colors + white, color fine-tuning, rotation with variable direction and speed
1 Rotation Gobo Wheel: 7 gobos + white, wheel rotation and shake
1 Static Gobo Wheel: 8 gobos + white, wheel rotation and shake
Prism: 8-facet Prism, bi-directional rotatable at variable speeds
Frost Effect
High-speed strobe effect with 1-25 flashes per second

Control Program
Control Signal: DMX 512, master-slave and sound activated or auto operation
Control Channel: 16/18 DMX Channels USITT DMX-512
Colorful LCD display

Pan And Tilt
Pan scan: 540° (16-bit precision scan)
Tilt scan: 270° (16-bit precision scan)
Automatic pan/tilt position correction

Electrical And Connectors
Input Voltage: AC90-260V 50/60Hz
Power Consumption: 350W
3-pin & 5-pin XLR connectors IN/OUT

Lighting Specifications
Length: 320 mm
Width: 220mm
Height: 480 mm
Product net weight: 13.50kg
Packaging size: 365(L)*280(W)*600(H)mm
Product gross weight: 16.50kg
Protection level: Ip20

技术参数

光源
250W 高输出白光 LED
50,000小时寿命和低功耗

光学系统
变焦角度5.5°~30°, 对焦功能
高光输出, 白光放大时13300LUX@5M, 白光缩小时950LUX@5M

控制措施和程序
色轮: 7种颜色+白色, 颜色微调, 可变方向和速度旋转
1个旋转图案轮: 7个图案+白光, 轮子旋转并抖动
1个静态图案轮: 8个图案片+白光, 轮子旋转和抖动
棱镜: 8面棱镜, 双向变速旋转
冰霜效果
每秒闪烁1-25次的高速频闪效果

控制程序
控制信号: DMX 512、主从、声控或自动操作
控制通道: 16/18 DMX 通道 USITT DMX-512
彩色液晶显示屏

X/Y轴
X轴扫描: 540° (16位精度扫描)
Y轴扫描: 270° (16位精度扫描)
自动X/Y轴位置校正

电气控制
输入电压: AC90-260V 50/60Hz
功耗: 350W
3针和5针 XLR 连接器输入/输出

照明规格
长度: 320毫米
宽度: 220毫米
高度: 480毫米
产品净重: 13.50kg
包装尺寸: 365(长)*280(宽)*600(高)mm
产品毛重: 16.50kg
防护等级: IP20



KL-BSW400

400W 光束/聚光/染色电脑灯

400W Beam/Spot/Wash Moving Head Light

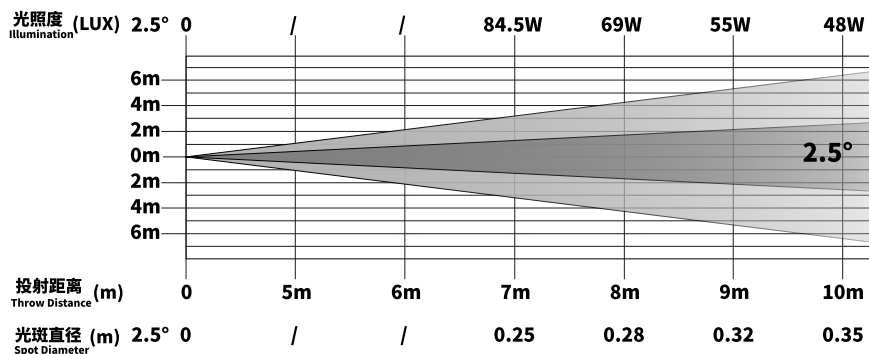
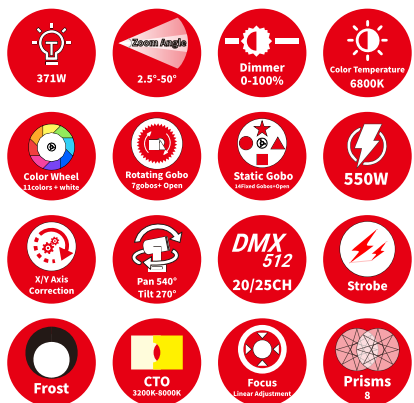

Technical Specifications

Light Source
Light source: 371W lamp
Life expectancy: 2,200 hours

Optical System
Lens: high-precision optical lens
Dimmer: Smooth dimming from 0-100%
Color temperature: 3200K-8000K linear adjustment
Zoom: 2.5°-52°
Linear Dimmer: Mechanical Dimmer 0-100%

Power Supply
Power supply with electronic auto ranging
Input voltage range: power supply 100-250V, 50/60Hz
Power Consumption: 550W

Functional Effect
Color plate: 11 colors + white
Rotating gobo wheel: 7 gobos + white light
Fixed gobo wheel: 14 fixed gobos + white light
Strobe: double-lens strobe (0.5-9 times/second)
Prism: 8 circular rotating prisms + multi-faceted prisms
Dimming: 0-100% linear dimming
Focus: linear adjustment
Frost Effect: atomizing mirror

Controls Program
Signal interface: optional three-core card base/five-pin card base
Support protocol: DMX512
DMX mode (20/25 control channels)
LCD operation
Built-in demo sequence
DMX data in/out: Locking 3-pin and 5-pin XLR
AC power input: 1.5m power cord with plug
powerful three-phase motor

Pan&Tilt Axis
Pan rotation angle: 540° (8/16 bit precision scanning)
Tilt rotation angle: 270° (8/16 bit precision scanning)
Pan&Tilt axis position correction

Lighting Specifications
Height: 570 mm
Width: 438mm
Depth: 260mm
Net weight: 19KG
Gross weight: 21KG
Protection class: IP20
Working environment: 0-45°C

技术参数

光源
光源: 371W灯泡
预期寿命: 2,200 小时

光学系统
镜头: 高精度光学镜头
调光器: 从 0-100% 平滑调光
色温: 3200K-8000K 线性调节
变焦: 2.5°-52°
线性调光器: 机械调光器 0-100%

电源
带电子自动量程的电源
输入电压范围: 电源 100-250V, 50/60Hz
功耗: 550W

功能效果
颜色盘: 11色+白色
旋转图案轮: 7个图案片+白光
固定图案轮: 14个固定图案+白光
频闪: 双镜头频闪 (0.5-9次/秒)
棱镜: 8个圆形旋转棱镜+多面棱镜
调光: 0-100%线性调光
调焦: 线性调节
雾化效果: 雾化镜

控制程序
信号接口: 可选三芯卡座/五针卡座
支持协议: DMX512
DMX模式 (20/25控制通道)
液晶操作
内置演示序列
DMX数据输入/输出: 锁定3针和5针XLR
交流电源输入: 1.5m带插头电源线
强大的三相电机

X/Y轴
X轴旋转角度: 540° (8/16位精度扫描)
Y轴旋转角度: 270° (8/16位精度扫描)
X/Y轴位置校正

灯具规格
高度: 570毫米
宽度: 438毫米
深度: 260毫米
净重: 19KG
毛重: 21KG
防护等级: IP20
工作环境: 0-45°C

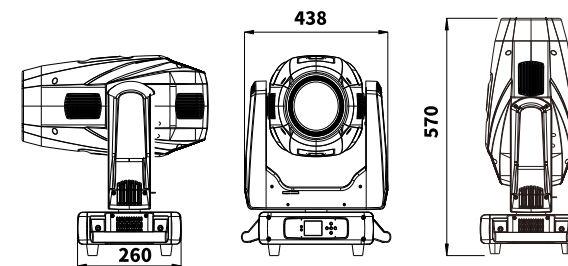

KL-BSW380/350

380/350W 光束/聚光/染色电脑灯

380/350W Beam/Spot/Wash Moving Head Light

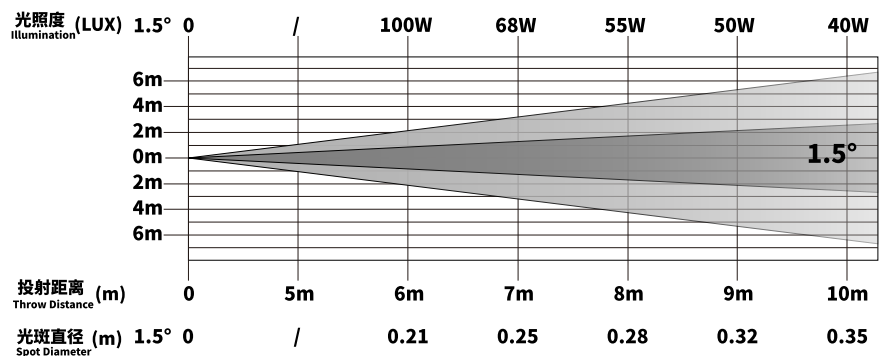

Technical Specifications

Light Source
 Light source specification: 371W/350W
 Life expectancy :1,500h

Optical System
 Color temperature: 3200K-8000K linear adjustment
 Lens: high-precision optical lens

Power Supply
 Input voltage: AC115/230V 50/60Hz
 Input power: 550W/500W
 Ballast: 350W multi-energy electronic ballast

Functional Effect
 Soft mirror: 8°--60° independent soft light
 Beam Angle:: 0-1.5°
 Focus angle: 1.5°--20° linearly adjustable
 Dimming: Dual dimming version dimming, super smooth and flicker-free dimming
 High-speed strobe: double-chip strobe, synchronous and asynchronous strobe. The strobe speed is 0.3-20 times per second adjustable speed
 Color wheel: 13 colors + white light
 Fixed pattern: 14 patterns + white light, two-way shaking, animation, running water
 Dynamic pattern: 9 patterns + white light + water ripple, with variable speed shaking effect, two-way variable speed
 Flow effect: the self-rotating gobo can be changed.
 Aperture function: with a macro command
 Prism: 8+6 (angle 10--20° can be scaled freely
 Focusing: Using a high-precision glass optical lens, linear electric focusing and zooming in

Controls Program
 Control mode: DMX/DRM/DMX antenna (optional)
 Channel mode: 19 channels in simplified mode, 24 channels in standard mode
 Display system: 2.5-inch touch LCD display, Chinese and English display, 180-degree rotation

Pan&Tilt Axis
 Pan rotation angle: 540° (2.9 seconds)
 Tilt rotation angle: 270° (1.5 seconds)
 Pan&Tilt axis position correction

Lighting Specifications
 Height: 635 mm
 Width: 420mm
 Depth: 295mm
 Net weight: 20KG
 Protection class: IP 20
 Working environment: 0-45°C

技术参数

光源
 光源规格:371W/350W 灯泡
 预期寿命:1,500h

光学系统
 色温:3200K-8000K线性调节
 镜头:高精度光学镜头

电源
 输入电压:AC115/230V 50/60Hz
 输入功率:550W/500W
 镇流器:350W多能电子镇流器

功能效果
 柔光镜:8°--60°独立柔光
 光束角度::0-1.5°
 聚焦角度:1.5°--20°线性可调
 调光:双调光版本调光,超平滑无闪烁调光
 高速频闪:双片频闪、同步、异步频闪。频闪速度每秒0.3-20次可调速
 色轮:13种颜色+白光
 固定图案:14种图案+白光、双向摇动、动画、流水
 动态图案:9种图案+白光+水波纹,带变速摇动效果,双向变速
 流动效果:可改变自转图案片。
 光圈功能:带宏命令
 棱镜:8+6(角度10--20°可自由缩放
 调焦:采用高精度玻璃光学镜头,线性电动调焦、变焦

控制程序
 控制模式:DMX/DRM/DMX天线(可选)
 通道模式:简化模式19通道,标准模式24通道
 显示系统:2.5英寸触摸液晶显示屏,中英文显示,180度旋转

X/Y轴
 X轴旋转角度:540°(2.9秒)
 Y轴旋转角度:270°(1.5秒)
 X/Y轴位置校正

照明规格
 高度:635毫米
 宽度:420毫米
 深度:295毫米
 净重:20KG
 防护等级:IP 20
 工作环境:0-45°C

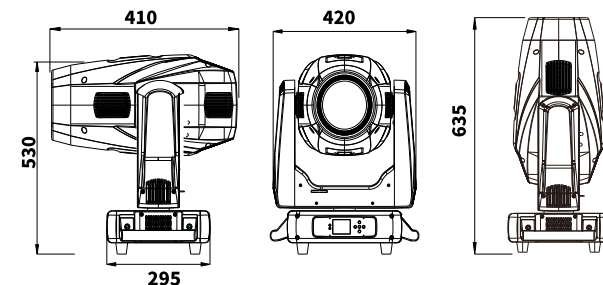

KL-BSW280

280W 光束/聚光/染色电脑灯

280W Beam/Spot/Wash Moving Head Light

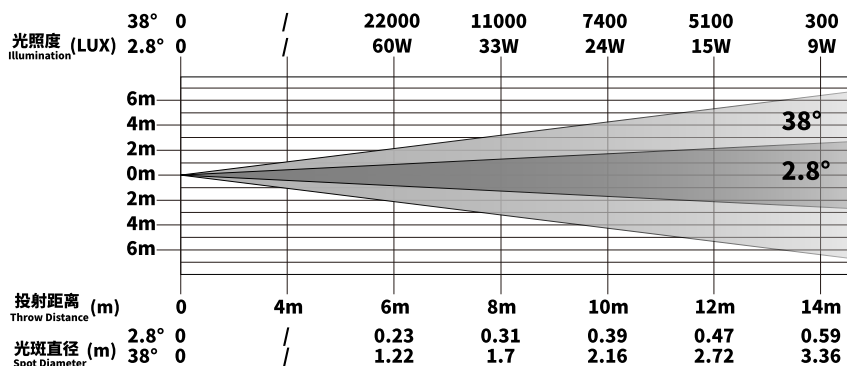
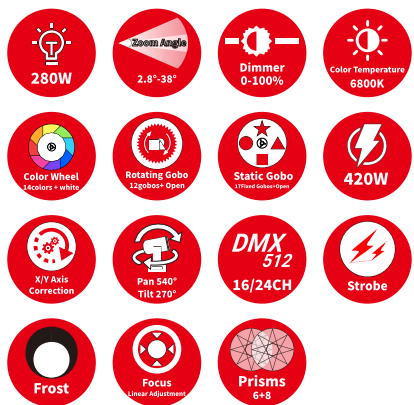

Technical Specifications

Light source
Light Source: 280W Bulb
Life expectancy: 2,000 hours

Optical System
The advanced optical system ensures clear, sharp image quality
A high-efficiency optical system, with a ratio of 1:6.4

Control & Program
4-touch buttons
Display: Color display
Protocols: DMX512
DMX modes: 2
Control channels: 16,24CH

PAN & TILT
Pan movement: 540°
Tilt movement: 270°
Pan/Tilt resolution: 16-bit
Automatic Pan/Tilt position correction

Rotating Gobos
1 x rotating gobo wheel with 12 gobos + open, convenient replacement
Thickness: 1.1mm
Borofloat (or better) glass materials
Slot & Lock system for Gobo replacement

Static Gobos
1x static gobo wheel with 17 gobos + open

Color Wheel
1x color wheel with 14 colors + open

Electrical & Connectors
Power supply with electronic auto-ranging
Input voltage range: AC 100-240V, 50/60Hz
Power consumption: 420W
Power connector input
Data in/out: 3-pin
Electronic ballast

Lighting Specification
Height: 570 mm
Width: 450 mm
Depth: 430 mm
Weight: 20 kg
Protection class: Ip20
Working environment: 0-45°C

技术参数

光源
光源: 280W灯泡
预期寿命: 2,000小时

光学系统
先进的光学系统确保清晰锐利的图像质量
高效光学系统, 光学倍率1:6.4

控制与程序
4点触控按钮
显示: 彩色显示
协议: DMX512
DMX模式: 2
控制通道: 16,24CH

X/Y轴
X轴运动: 540°
Y轴运动: 270°
X/Y轴分辨率: 16位
X/Y轴自动位置校正

旋转图案片
1个旋转图案轮, 12个图案+白光, 方便更换
厚度: 1.1毫米
Borofloat (或更好) 玻璃材料
用于更换图案片的槽和锁系统

静态图案片
1x 静态图案轮, 带 17 个图案片 + 白光

色轮
1x 色轮, 14 种颜色 + 打开

电气与连接器
带电子自动量程的电源
输入电压范围: AC 100-240V, 50/60Hz
功耗: 420W
电源连接器输入
数据输入/输出: 3针
电子镇流器

照明规格
高度: 570毫米
宽度: 450毫米
深度: 430毫米
重量: 20公斤
防护等级: IP20
工作环境: 0-45°C

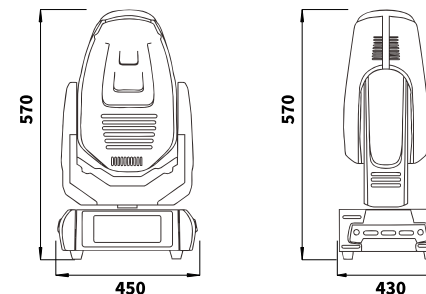

KL-MB480

480W 光束电脑灯

480W Beam Moving Head Light

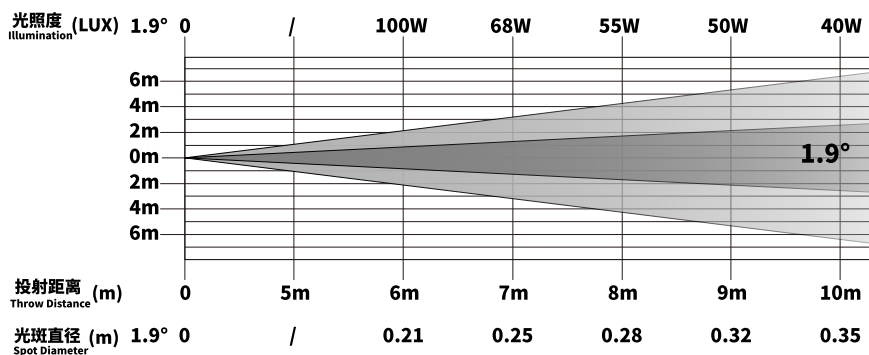
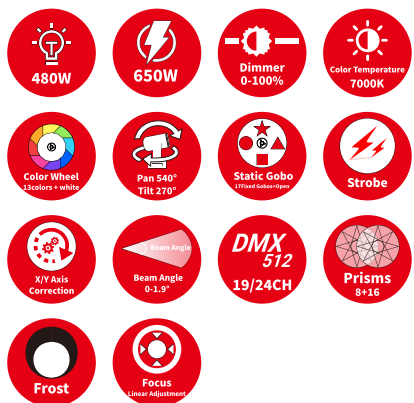

Technical Specifications

Light Source
Light source: 480W
Life expectancy: 2,000 hours

Optical System
Luminous flux: 29000LM
Light output angle: 1.9°
Color temperature: 7000K
Lens diameter: 180MM
Lens: high-precision optical lens

Power Supply
Input voltage: AC115/230V 50/60Hz
Input power: 650W

Functional Effect
Color wheel: 13 colors + white light, two-way variable speed rainbow effect
Gobo wheel: 17 fixed gobos + white light
Atomization: 1 atomizing mirror
Double prism: 8-16 prism bidirectional variable speed rotation
Dimming: 0-100% linear adjustment
Strobe: 1-13 times/second
Focus: electronic focus
Controls and Procedures
Control mode: DMX/DRM/DMX antenna (optional)
Channel mode: 19 channels in simplified mode, 24 channels in standard mode
Display system: LED touch screen can be rotated 180 degrees

Pan&Tilt Axis
Pan rotation angle: 540° (8/16 bits)
Tilt rotation angle: 270° (8/16 bits)
Pan&Tilt axis position correction

Lighting Specifications
Height: 640mm
Width: 400 mm
Depth: 285mm
Net weight: 21.5KG
Protection class: IP20
Working environment: 0-45°C

技术参数

光源
光源:480W
预期寿命:2,000小时

光学系统
光通量:29000LM
出光角度:1.9°
色温:7000K
镜片直径:180MM
镜头:高精度光学镜头

电源
输入电压:AC115/230V 50/60Hz
输入功率:650W

功能效果
色轮:13种颜色+白光, 双向变速彩虹效果
图案轮:17个固定图案+白光
雾化:1个雾化镜
双棱镜:8-16棱镜双向变速旋转
调光:0-100%线性调节
频闪:1-13次/秒
调焦方式:电子调焦
控制措施和程序
控制模式:DMX/DRM/DMX天线(可选)
通道模式:简化模式19通道, 标准模式24通道
显示系统:LED触摸屏可180度旋转

X/Y轴
X轴旋转角度:540° (8/16位)
Y轴旋转角度:270° (8/16位)
X/Y轴位置校正

灯具规格
高度:640毫米
宽度:400毫米
深度:285毫米
净重:21.5KG
防护等级:IP20
工作环境:0-45°C

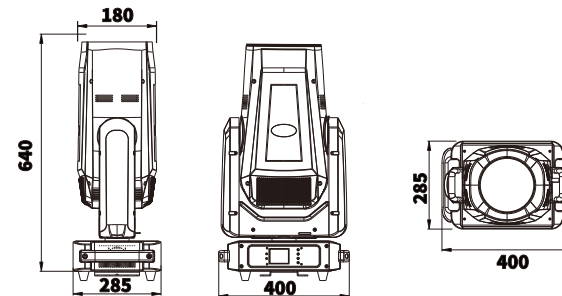

KL-MB380/350

380/350W 光束电脑灯

380/350W Beam Moving Head Light

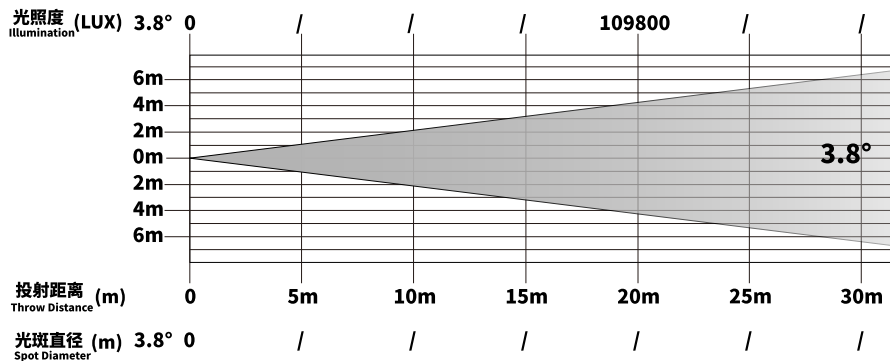
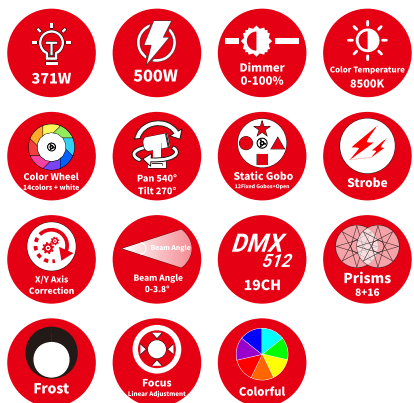

Technical Specifications

Light Source
 Light source: 371W/350W
 Average lifespan: 2,000H (bulbs and reflectors are packaged as a whole with higher light efficiency and longer service life)

Optical System
 Lumen value: 109800 lux@ 20 meters
 Color temperature: 8500K
 Beam Angle: Parallel Beam Angle: 0-3.8°
 Smart bulb switch control (extends bulb life)

Power Supply
 Power supply: AC100V-240V 50-60Hz
 Power: 500W
 Fuses: 5A

Functional Effect
 Dimming: 0-100% linear adjustment; overheating intelligent protection
 Strobe: double-chip strobe (0.5-9 times/second), complete linear dimming, and variable strobe speed
 Color wheel: with 14 colors + blank (can create sharp aerial beam effect)
 Gobo wheel: with 12 fixed gobos + blank (allows you to quickly change the shape of the beam)
 Prism: rotating 8-sided prism and 16-sided prism
 Colorful effect can be rotated in both directions and the speed of rotation can be adjusted to make the pattern projection effect more abundant
 Atomization: Atomization enlarges the soft light effect, easily achieves a soft and dreamy pattern effect, and the proportion of atomization is enlarged
 Anti-shooting high-temperature internal treatment design structure
 Focusing: Using 2 sets of optical lens combinations, the effect is far better than the usual beam light and can project high-definition patterns

Controls Program
 Number of motors: a total of 13 silent motors
 International standard control signal: DMX512
 Number of channels: 19CH

Pan&Tilt Axis
 Pan rotation angle: 540° (8/16 bits)
 Tilt rotation angle: 270° (8/16 bits)
 Pan&Tilt axis position correction

Lighting Specifications
 Height: 580 mm
 Width: 320 mm
 Depth: 220mm
 Net weight: 20.35KG
 Protection class: Ip20
 Working environment: 0-45°C

技术参数

光源
 光源: 371W/350W
 平均寿命: 2000H (灯泡与反光罩为一体封装, 光效更高, 使用寿命更长)

光学系统
 流明值: 109800 lux@20米
 色温: 8500K
 光束角: 平行光束角: 0-3.8°
 智能灯泡开关控制 (延长灯泡寿命)

电源
 电源: AC100V-240V 50-60Hz
 功率: 500W
 保险丝: 5A

功能效果
 调光: 0-100%线性调节; 过热智能保护
 频闪: 双片频闪 (0.5-9次/秒), 完全线性调光, 频闪速度可变
 色轮: 14种颜色+空白 (可打造锐利的空中光束效果)
 图案轮: 带有12个固定图案片+空白 (可让您快速改变光束形状)
 棱镜: 旋转8棱镜和16棱镜
 彩色效果: 可对向旋转且旋转速度可调, 使图案投影效果更加丰富
 雾化: 雾化放大柔光效果, 轻松实现柔和梦幻的图案效果, 雾化比例放大
 内部防高温处理设计结构
 调焦: 采用2组光学透镜组合, 效果远优于通常光束灯, 可投射出高清图案

控制程序
 电机数量: 静音电机共13个
 国际标准控制信号: DMX512
 通道数: 19CH

X/Y轴
 X轴旋转角度: 540° (8/16位)
 Y轴旋转角度: 270° (8/16位)
 X/Y轴位置校正

灯具规格
 高度: 580毫米
 宽度: 320毫米
 深度: 220毫米
 净重: 20.35KG
 防护等级: IP20
 工作环境: 0-45°C

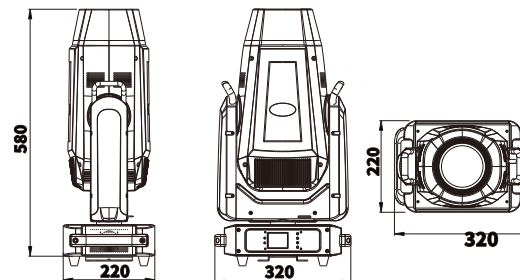

KL-MB295

295W 光束电脑灯

295W Beam Moving Head Light

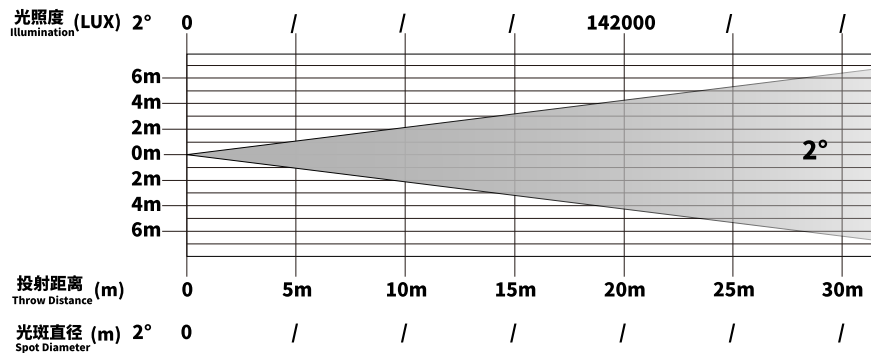
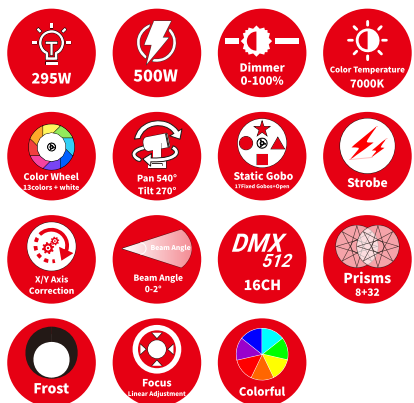

Technical Specifications

Light Source
Light source: 295W
Life expectancy: 1,500 hours

Optical System
Ballast: Electronic Ballast
Lens: Anti-reflective coated glass lens
Focus: Linear Motorized focus
Dimmer: 0-100% linear dimming
Beam Angle: 2 degree
High light output 142000LUX@20M

Control Program
Prism: 8-facet prism and 32 facets Prism, bi-directional
rotatable at variable speeds
Frost effect+Rainbow effect
Strobe: 0-20 times/second
Motor: 3-phase motor
A fan with a speed control board can effectively reduce noise, protect the light

PAN & TILT
Pan movement: 540°
Tilt movement: 270°
Automatic Pan/Tilt position correction

Gobos Wheel
1 Rotation Gobo Wheel: 17 gobos + white, wheel rotation and shake

Color Wheel
Color Wheel: 13 colors +white, color fine-tuning, rotation with variable direction and speed, with a rainbow effect

Electrical & Connectors
Power supply with electronic auto-ranging
Voltage: AC90-250V 50/60Hz
Power: 500W
PowerCon IN/OUT
3-pin & 5-pin XLR connectors IN/OUT
Cooling System: No noise fan

Lighting Specification
Height: 590 mm
Width: 480 mm
Depth: 410 mm
Weight: 18kg
Gross Weight:20KG
IP Grade: IP20

技术参数

光源
光源: 295W
预期寿命: 1,500小时

光学系统
镇流器: 电子镇流器
镜片: 防反射镀膜玻璃镜片
调焦: 线性电动调焦
调光器: 0-100%线性调光
光束角: 2度
高光输出142000LUX@20M

控制程序
棱镜: 8面棱镜和32面棱镜, 双向可变速旋转
冰霜效果+彩虹效果
频闪: 0-20次/秒
电机: 三相电机
带调速板的风扇可有效降低噪音, 保护光线

X/Y轴
X轴运动: 540°
Y轴运动: 270°
X/Y轴自动位置校正

图案轮
1个旋转图案轮: 17个图案片+白光, 轮子旋转并摇动

色轮
色轮: 13种颜色+白色, 颜色微调, 双向变速旋转, 具有彩虹效果

电气程序
带电子自动量程的电源
电压: AC90-250V 50/60Hz
功率: 500W
电源输入/输出
3针和5针 XLR 连接器输入/输出
冷却系统: 无噪音风扇

照明规格
高度: 590毫米
宽度: 480毫米
深度: 410毫米
重量: 18公斤
毛重: 20KG
防护等级: IP20

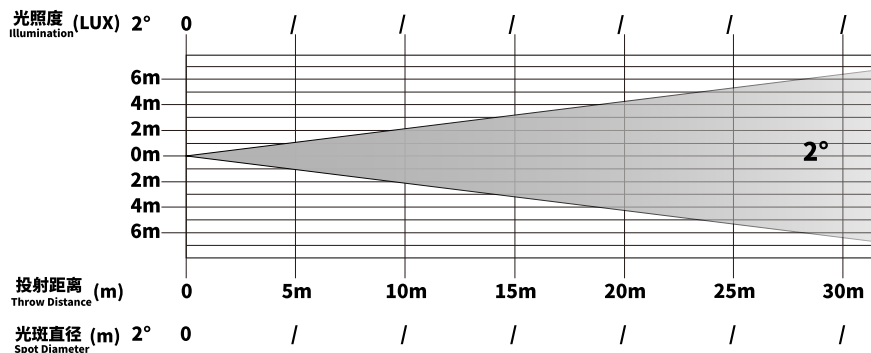
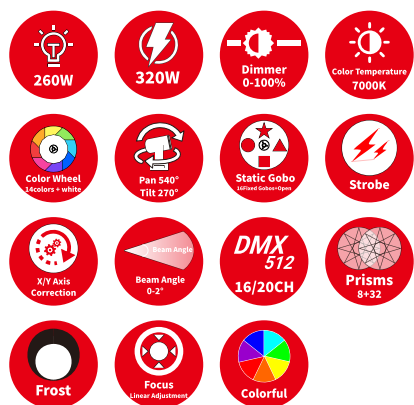

KL-MB260**260W 光束电脑灯****260W Beam Moving Head Light****Technical Specifications**

Light Source
Light Source: 260W
Life expectancy: 2,000 hours

Optical System
The advanced optical system ensures clear, sharp image quality
High-efficiency optical system
Beam angle: 2°

Control & Program
4-button touch panel
Display: Color display
Protocols: DMX512, Master/Slave
Control channels: 16CH, 20CH
Electronic ballast

PAN & TILT
Pan movement: 540°
Tilt movement: 270°
Pan/Tilt resolution: 16-bit
Automatic Pan/Tilt position correction

Static Gobos
1x static gobo wheel with 16 gobos plus open

Color Wheel
1x color wheel with 14 colors plus white

Electrical & Connectors
Power supply with electronic auto-ranging
Input voltage range: AC 100-240V, 50/60Hz
Power consumption: 320W
Data in/out: 3-pin XLR

Lighting Specification
Height: 565 mm
Width: 350 mm
Depth: 253 mm
Weight: 17kg

技术参数

光源
光源: 260W
预期寿命: 2,000小时

光学系统
先进的光学系统确保清晰锐利的图像质量
高效光学系统
光束角: 2°

控制与程序
4键触摸屏
显示: 彩色显示
协议: DMX512, 主/从
控制通道: 16CH、20CH
电子镇流器

X/Y轴
X/Y轴运动: 540° 16位
X/Y轴运动: 270° 16位
X/Y轴自动位置校正

静态图案盘
1x 静态图案盘, 带 16 个图案片加白光

颜色盘
1x 颜色盘, 14 种颜色加白色

电气控制
带电子自动量程的电源
输入电压范围: AC 100-240V, 50/60Hz
功耗: 320W
数据输入/输出: 3针XLR

灯具规格
高度: 565毫米
宽度: 350毫米
深度: 253毫米
重量: 17公斤



KL-MB250

250W 光束电脑灯

250W Beam Moving Head Light

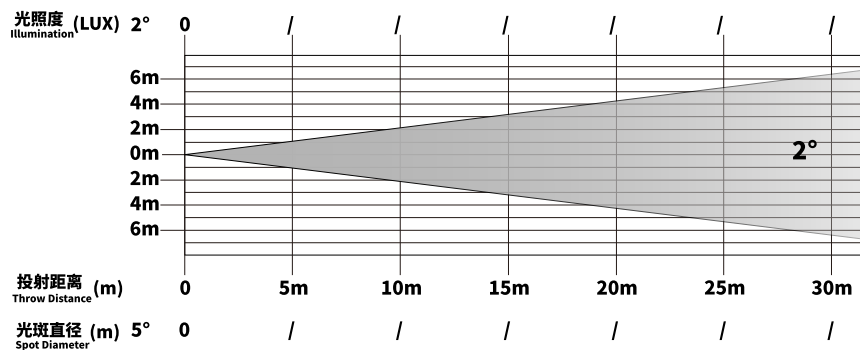
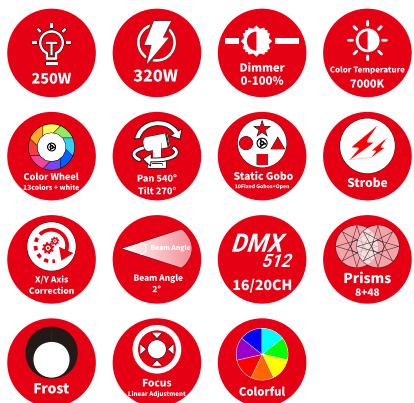

Technical Specifications

Light Source
Light source: 250W
Life expectancy: 2,000 hours

Optical System
Ballast: Electronic Ballast
Lens: Anti-reflective coated glass lens
Focus: Linear Motorized focus
Dimmer: 0-100% linear dimming
Beam Angle: 2 degree
High light output 142000LUX@ 20M

Function Effect
Prism: one 8 prism and one 48 prism as standard, 8/16/24/48 prism optional
Focusing: Electronic focusing
Atomization: with atomization function
Colorful: there are colorful effects
Strobe: 0-10 times / second, speed adjustable

Control Program
Motor: 3-phase motor
A fan with a speed control board can effectively reduce noise, protect the light
Channel: 20/16 channels can be switched
Display: LCD display, switchable Chinese and English
System version V3.006 with RDM function

PAN & TILT
Pan movement: 540°
Tilt movement: 270°
Automatic Pan/Tilt position correction

Gobos Wheel
Pattern: 10 fixed patterns + 1 dynamic pattern + white light

Color Wheel
Color: 13 colors + white light, with half-color effect, with rainbow effect

Electrical & Connectors
Voltage: AC110V—240V 50/60Hz
Total power 320W
Fuse: 7A
PowerCon IN/OUT
3-pin & 5-pin XLR connectors IN/OUT
Cooling System: No noise fan

Lighting Specification
Height: 602 mm
Width: 415 mm
Depth: 323 mm
Weight: 18kg
Gross Weight: 15KG
IP Grade: IP20

技术参数

光源
光源: 250W
预期寿命: 2,000小时

光学系统
镇流器: 电子镇流器
镜片: 防反射镀膜玻璃镜片
调焦: 线性电动调焦
调光器: 0-100%线性调光
光束角: 2度
高光输出142000LUX@20M

功能效果
棱镜: 标配1个8棱镜, 8/16/24/48棱镜可选
调焦: 电子调焦
雾化: 具有雾化功能
七彩: 有七彩效果
频闪: 0-10次/秒, 速度可调

控制程序
电机: 三相电机
带调速板的风扇可有效降低噪音, 保护光线
通道: 20/16通道可切换
显示: 液晶显示, 中英文可切换
系统版本V3.006 带RDM功能

X轴运动: 540°
Y轴运动: 270°
X/Y轴自动位置校正

图案轮
图案: 10个固定图案+1个动态图案+白光

色轮
颜色: 13色+白光, 带半色效果, 带彩虹效果

电气和连接器
电压: AC110V—240V 50/60Hz
总功率: 320W
保险丝: 7A
电源输入/输出
3针和5针 XLR 连接器输入/输出
冷却系统: 无噪音风扇

照明规格
高度: 602毫米
宽度: 415毫米
深度: 323毫米
重量: 18公斤
毛重: 15KG
防护等级: IP20



KL-MB230

230W 光束电脑灯

230W Beam Moving Head Light

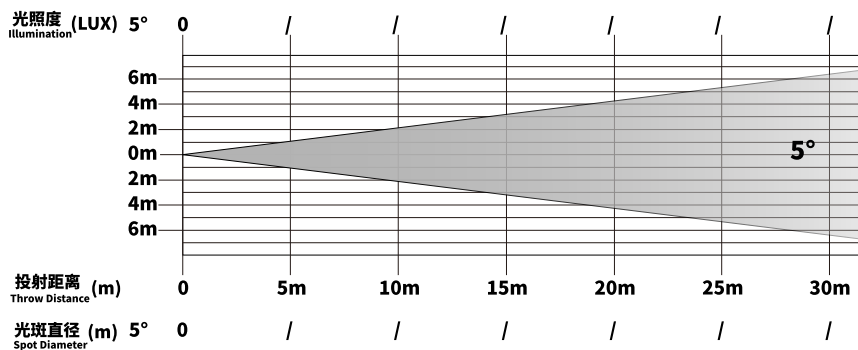
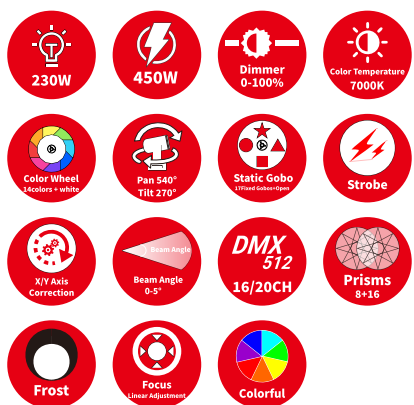

Technical Specifications

Light Source
Light source: 230WBulb

Optical System
Optical equipment: 3-lens combination coating lens group,
zoom: 0-5°

Power Supply
Voltage: AC100V-240V 50/60Hz
Power: 450W

Functional Effect
Color wheel: 14 color chips + white light, with a two-way rotating rainbow effect
Gobo wheel: 17 gobos + white light, with gobo shake and gobo arbitrary positioning function
Prism disc: 16+8 prisms/1 prism, prisms are optional and can be rotated in both positive and negative directions
Strobe: Double steel knife strobe frequency up to 13 times per second, and random strobe and pulse strobe can be selected
Dimming: 0%-100% linear dimming
Atomization: 0%-100% linear atomization
Built-in macro function
The dimming range is 0-100% adjustable

Controls Program
Channel mode: international standard DMX512 channels, 16/18 channels
Master-slave self-propelled automatic synchronization function.
The console normally controls self-propelled permanent synchronization.
It can realize the function of remote pointing and defoaming.
Equipped with DMX512 interface.
Built-in program self-propelled function.
Master-slave online mode.
Panel display: LCD liquid crystal display

Pan&Tilt Axis
Pan rotation angle: 540° (8/16 bits)
Tilt rotation angle: 270° (8/16 bits)
Pan&Tilt axis position correction

Lighting Specifications
Height: 520 mm
Width: 410mm
Depth: 330mm
Net weight: 16KG
Protection class: IP20
Working environment: 0-45°C

技术参数

光源
光源:230W灯泡

光学系统
光学设备:3片组合镀膜镜片组,
变焦:0-5°

电源
电压:AC100V-240V 50/60Hz
功率:450W

功能效果
颜色轮:14个色片+白光,具有双向旋转彩虹效果
图案轮:17个图案+白光,具有图案抖动和图案任意定位功能
棱镜盘:16+8棱镜/1棱镜,棱镜可选,可正反方向旋转
频闪:双钢刀频闪频率可达每秒13次,可选择随机频闪和脉冲频闪
调光:0%-100%线性调光
雾化:0%-100%线性雾化
内置宏功能
调光范围0-100%可调

控制程序
通道模式:国际标准DMX512通道,16/18通道
主从自走自动同步功能。
控制台通常控制自走永久同步。
可实现远程指向、消泡功能。
配备DMX512接口。
内置程序自走功能。
主从联机模式。
面板显示:LCD液晶显示

X/Y轴
X轴旋转角度:540° (8/16位)
Y轴旋转角度:270° (8/16位)
X/Y轴位置校正

灯具规格
高度:520毫米
宽度:410毫米
深度:330毫米
净重:16KG
防护等级:IP20
工作环境:0-45°C



KL-ML150

150W LED 光束电脑灯

150W LED Beam Moving Head Light

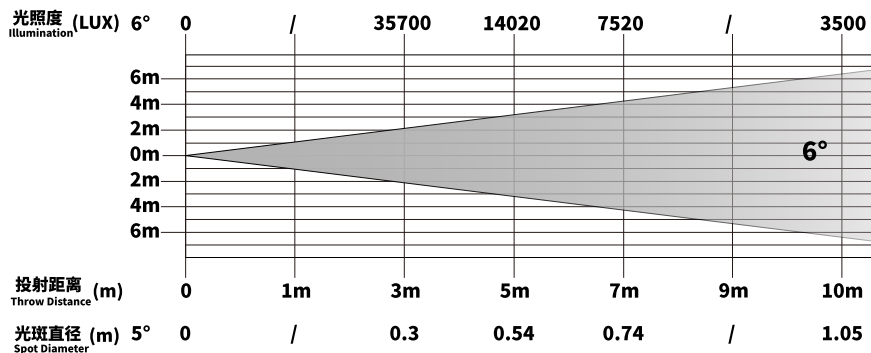
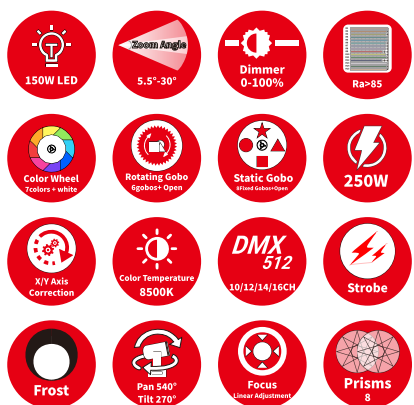

Technical Specifications

Light Source
150W High Output White LED
50,000 hours lifespan and low power consumption

Optical System
Beam Angle 6°, Outstanding sharp BEAM effect and remarkable wash effect with pure color mixing and focus function
High light output, 14020LUX@5M at White light

Controls Program
Color Wheel: 7 colors +white, rotation with variable direction and speed
1 static Gobo Wheel: 8 gobos +white, wheel rotation, and shake
1 Rotate Gobo Wheel: 6 gobos +white, wheel rotation, and shake
Prism: 8-facet Prism, bi-directionally rotatable at variable speeds
High-speed strobe effect with 1-25 flashes per second

Control Program
16/14/12/10 DMX Channels USITT DMX-512
DMX 512, master-slave and sound activated controllable or auto operation
Specific computer control software is optional
Colorful LCD display

Pan And Tilt
Horizontal scan: 540° (16-bit precision scan)
Vertical scan: 270° (16-bit precision scan)
Automatic pan/tilt position correction

Electrical And Connectors
Input Voltage: AC90-260V 50/60Hz
Light Source: 150W High Output White LED
Power Consumption: 250W

Fixture Specifications
Length: 270 mm
Width: 270 mm
Height: 470 mm
Product Net Weight: 10.6kg
Packing Dimensions: 305(D)*305(W)*500(H)mm
Product Gross Weight: 12.6kg

技术参数

光源
150W 高输出白光 LED
50,000小时寿命和低功耗

光学系统
光束角6°, 出色的锐利BEAM效果和显著的染色效果, 具有纯色混合和聚焦功能
高光输出, 白光下 14020LUX@5M

控制程序
色轮: 7种颜色+白色, 可变方向和速度旋转
1个静态图案轮: 8个图案+白光, 轮子旋转, 摇动
1 旋转图案轮: 6个图案+白光, 轮旋转, 摇动
棱镜: 8棱镜, 双向变速旋转
每秒闪烁1-25次的高速频闪效果

控制程序
16/14/12/10 DMX 通道 USITT DMX-512
DMX 512, 主从和声控可控或自动操作
可选配专用电脑控制软件
彩色液晶显示屏

X/Y轴
X轴扫描: 540° (16位精度扫描)
Y轴扫描: 270° (16位精度扫描)
X/Y轴自动位置校正

电气连接
输入电压: AC90-260V 50/60Hz
光源: 150W 高输出白光 LED
功耗: 250W

夹具规格
长度: 270毫米
宽度: 270毫米
高度: 470毫米
产品净重: 10.6kg
包装尺寸: 305(深)*305(宽)*500(高)mm
产品毛重: 12.6kg



KL-ML1915B

19颗*15W LED 调焦大蜂眼摇头灯

19PCS*15W LED Bee Eye Moving Light

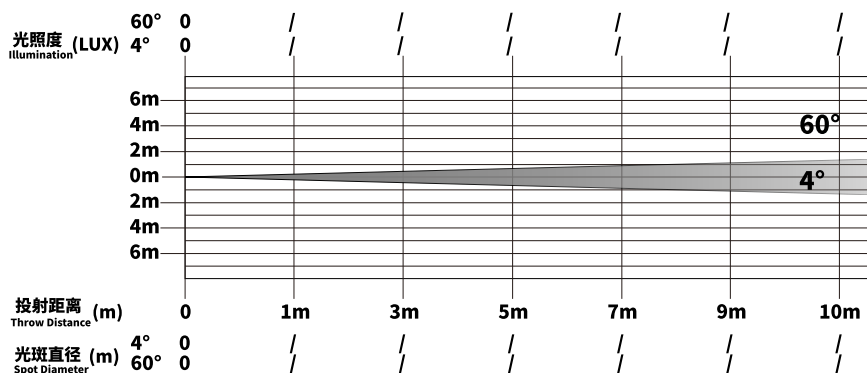
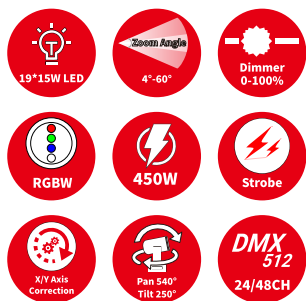

Technical Specifications

Light Source
 Light source: 19x15W RGBW LED
 LED life expectancy: 20,000 hours

Optical System
 The advanced optical system ensures a clear and wide-ranging beam & washing effect
 High-efficiency zoom optical system, ratio 1:6
 Beam Angle: 4° - 60°

Controls Program
 Display: LCD display
 Protocol: DMX512
 Control channel: built-in 6-channel modes 23CH (normal)/21CH (standard)/35CH (image)/78CH (extendable)/96CH (RGBW extensible)/92CH (all)
 Dimmer: 16 bits
 Dimming: 0-100% linear dimming
 Strobe: 1-20 times/second with various strobe effects

Pan/Tilt Axis
 Pan axis movement: 540° 16-bi
 Tilt axis movement: 250° 16-bi
 Automatic pan/tilt position correction

Electrical Control
 Power supply with electronic auto-ranging
 Input voltage range: AC 100-240 V, 50/60 Hz
 Power Consumption: 450W

Lighting Specifications
 Height: 425 mm
 Width: 415 mm
 Depth: 275 mm
 Net Weight: 14.95 kg
 Gross weight: 18.1 kg

技术参数

光源
 光源: 19x15W RGBW LED
 LED寿命: 20,000小时

光学系统
 先进的光学系统确保清晰以及宽范围的光束和洗涤效果
 高效变焦光学系统, 变焦比1:6
 光束角: 4° - 60°

控制程序
 显示: 液晶显示
 协议: DMX512
 控制通道: 内置6通道模式23CH (普通)/21CH (标准)/35CH (图像)/78CH (可扩展)/96CH (RGBW可扩展)/92CH (全部)
 调光器: 16位
 调光: 0-100%线性调光
 频闪: 1-20次/秒多种
 频闪效果

X/Y轴
 X轴运动: 540° 16-bi
 Y轴运动: 250° 16-bi
 X/Y轴自动位置校正

电气控制
 带电子自动量程的电源
 输入电压范围: AC 100-240 V, 50/60 Hz
 功耗: 450W

灯具规格
 高度: 425毫米
 宽度: 415毫米
 深度: 275毫米
 净重: 14.95公斤
 毛重: 18.1公斤



KL-ML760B

7颗*60W LED 调焦大蜂眼摇头灯

7PCS*60W LED Bee Eye Moving Light

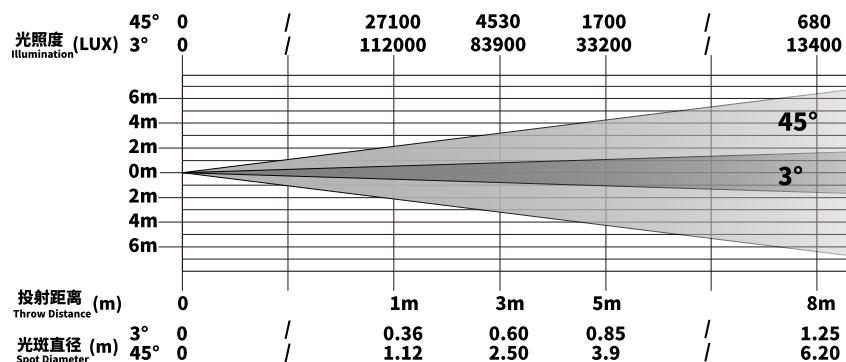
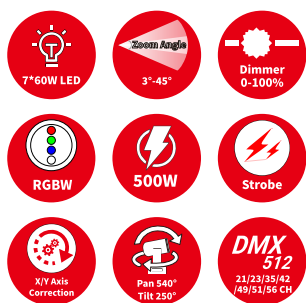

Technical Specifications

Light Source
7*60W 4IN1 RGBW LED
50,000 hours lifespan and low power consumption

Optical System
Beam Angle:3°- 45°
Dimmer:0~100% smooth dimming; two dimmer models in optional(delay or without delay)

Controls Program
DMX Channel: 21/23/35/42/49/51/56CH
Control Modes: DMX512/masterslave/ AutoRun/Music
Maximum number of connections: 220V: Within 8 units, the wire needs 2.5 square meters /120V: Within 4 units, the wire needs 2.5 square meters
Display: 1.8-inch TFT color LCD display, 180-degree rotatable

Pan And Tilt
Pan axis movement: 540°
Tilt axis movement: 270°
Pan/Tilt Resolution: 8/16 bit
Automatic pan/tilt position correction

Electrical Control
Power Consumption: 500W
Power Voltage: AC 100-260V, 50/60Hz
Data In/Out socket: 3-pin & 5-pin XLR sockets
Power Socket: Powercon in/out

Lighting Specifications
Length:376mm
Width: 280mm
Height: 422.5 mm
Product Net Weight: 16.5kg
Gross weight: 64.5kg

技术参数

光源
7颗60W 4合1 RGBW LED
50,000小时寿命和低功耗

光学系统
光束角:3°- 45°
调光器:0~100%平滑调光; 二
调光型号可选(延时或不延时)

控制程序
DMX通道: 21/23/35/42/49/51/56CH
控制模式:DMX512/主从/
自动运行/音乐
最大连接数量:220V:8台以内, 电线需要2.5平方米 /120V:4台以内, 电线需要2.5平方米
显示屏:1.8英寸TFT彩色液晶显示屏, 180度可旋转

X/Y轴
X轴运动:540°
Y轴运动:270°
X/Y轴分辨率:8/16 位
X/Y轴自动位置校正

电气控制
功耗:500w
电源电压:AC 100-260V, 50/60Hz
数据输入/输出插座:3针和5针XLR插座
电源插座:Powercon 输入/输出

灯具规格
长度:376毫米
宽度:280毫米
高度:422.5毫米
产品净重:16.5kg
毛重:64.5kg

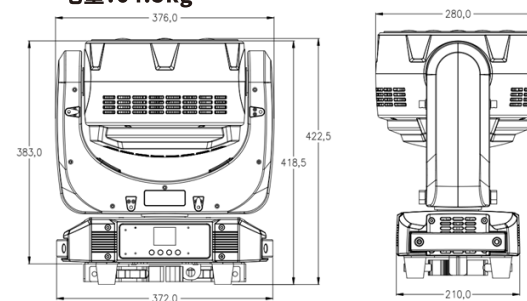

KL-ML660Z

6颗*60W LED 调焦摇头灯

6PCS*60W LED Zoom Moving Light

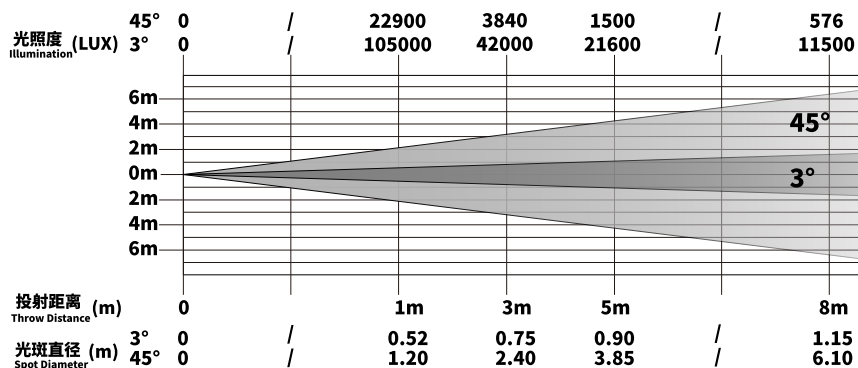
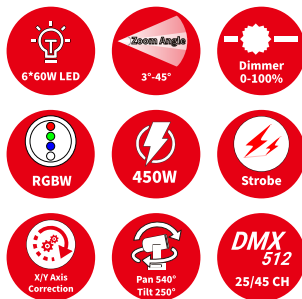

Technical Specifications

Light Source
7*60W 4IN1 RGBW LED
50,000 hours lifespan and low power consumption

Optical System
Beam Angle:3°- 45°
Dimmer:0~100% smooth dimming; two dimmer models in optional(delay or without delay)

Controls Program
DMX Channel: 21/23/35/42/49/51/56CH
Control Modes:
DMX512/masterslave/AutoRun/Music
Maximum number of connections: 220V: Within 8 units, the wire needs 2.5 square meters /120V: Within 4 units, the wire needs 2.5 square meters
Display: 1.8-inch TFT color LCD display, 180-degree rotatable

Pan And Tilt
Pan axis movement: 540°
Tilt axis movement: 270°
Pan/Tilt Resolution: 8/16 bit
Automatic pan/tilt position correction

Electrical Control
Power Consumption: 500W
Power Voltage: AC 100-260V, 50/60Hz
Data In/Out socket: 3-pin & 5-pin XLR sockets
Power Socket: Powercon in/out

Lighting Specifications
Length:376mm
Width: 280mm
Height: 422.5 mm
Product Net Weight: 16.5kg
Gross weight: 64.5kg

技术参数

光源
7颗60W 4合1 RGBW LED
50,000小时寿命和低功耗

光学系统
光束角:3°- 45°
调光器:0~100%平滑调光;两种调光型号可选(延时或不延时)

控制程序
DMX通道:21/23/35/42/49/51/56CH
控制模式:DMX512/主从/自走/音乐
最大连接数量:220V:8台以内, 电线需要2.5平方米 /120V:4台以内, 电线需要2.5平方米
显示屏:1.8英寸TFT彩色液晶显示屏, 180度可旋转

X/Y轴
X轴运动:540°
Y轴运动:270°
X/Y轴分辨率:8/16位
X/Y轴自动位置校正

电气控制
功耗:500W
电源电压:AC 100-260V, 50/60Hz
数据输入/输出插座:3针和5针XLR插座
电源插座:Powercon 输入/输出

灯具规格
长度:376毫米
宽度:280毫米
高度:422.5毫米
产品净重:16.5kg
毛重:64.5kg

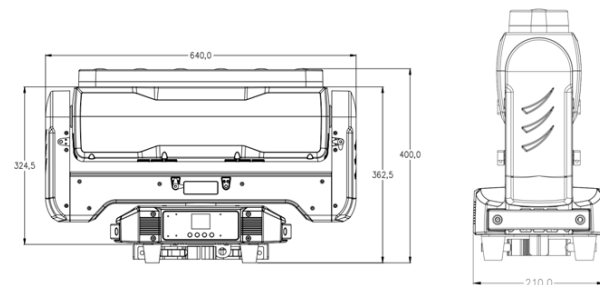

KL-ML3715W

37颗*15W LED 调焦摇头染色灯

37PCS*15W LED Zoom Wash Moving Light

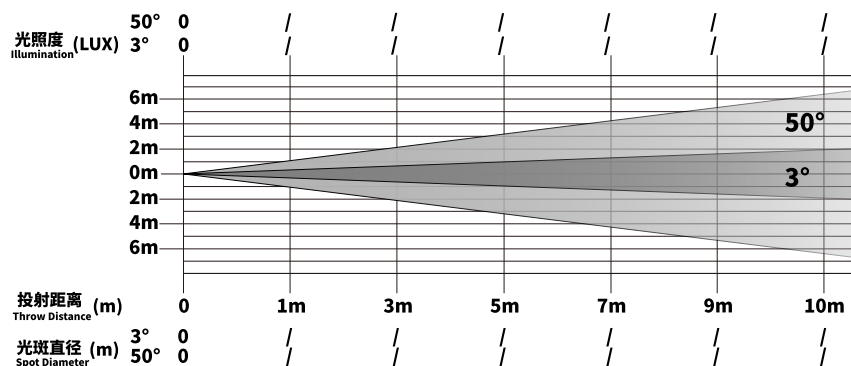
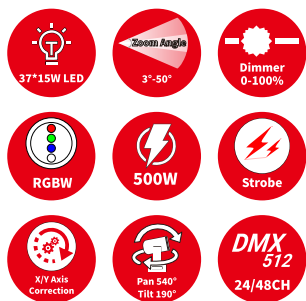

Technical Specifications

Light Source

Light source: 37x15W RGBA LED
LED life expectancy: 20,000 hours

Optical System

The advanced optical system ensures a clear and wide-ranging beam&washing effect
High-efficiency zoom optical system, ratio 1:6
Zoom range: 3° - 50°

Controls Program

Display: LCD display
Protocol: DMX512
DMX protocol mode: 4
Control channel: 24CH/48CH
Dimmer: 16 bits

Pan/Tilt Axis

Pan axis movement: 540°
Tilt axis movement: 190°
Pan/Tilt Resolution: 16-bit
Automatic pan/tilt position correction

Electrical and Connectors

Power supply with electronic auto-ranging
Input voltage range: AC 100-240 V, 50/60 Hz
Power Consumption: 500W
Power connector input
Data In/Out: 3-pin XLR

Lighting Specifications

Height: 560 mm
Width: 490 mm
Depth: 440 mm
Net weight: 12.7 kg
Gross weight: 15 kg

working environment

Maximum ambient temperature: 40°C
Maximum surface temperature: 65°C
Minimum operating temperature: 0°C

技术参数

光源

光源: 37x15W RGBA LED
LED预期寿命: 20,000小时

光学系统

先进的光学系统确保清晰、光束范围广,染色效果好
高效变焦光学系统,比例1:6
变焦范围: 3° - 50°

控制程序

显示: 液晶显示
协议: DMX512
DMX协议模式: 4种
控制通道: 24CH/48CH
调光器: 16位

X/Y轴

X轴运动: 540° 16位
Y轴移动: 190° 16位
X/Y轴自动位置校正

电气和连接器

带电子自动量程的电源
输入电压范围: AC 100-240 V, 50/60 Hz
功耗: 500W
电源连接器输入
数据输入/输出: 3针 XLR

灯具规格

高度: 560毫米
宽度: 490毫米
深度: 440毫米
净重: 12.7公斤
毛重: 15公斤

工作环境

最高环境温度: 40°C
最高表面温度: 65°C
最低工作温度: 0°C





KL-ML1915W

19颗*15W LED 调焦摇头染色灯

19PCS*15W LED Zoom Wash Moving Light

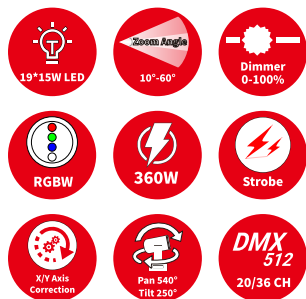

Technical Specifications

Light Source

Light source: 19PCS*15W RGBA LED
LED life expectancy: 20,000 hours

Optical System

The advanced optical system ensures a clear and large-range beam & wash effect
High-efficiency zoom optical system, ratio 1:6
Zoom range: 10°-60°

Control Program

Display: LCD display
Protocols: DMX512
Control channels: 20/36CH
Dimmer: 16-bit, 0-100%

PAN & TILT

Pan movement: 540°
Tilt movement: 270°
Pan/Tilt Resolution: 16-bit
Automatic Pan/Tilt position correction

Electrical Control

Power supply with electronic auto-ranging
Input voltage range: AC 100-240V, 50/60 Hz
Power consumption: 360W

Lighting Specification

Height: 380 mm
Width: 250 mm
Depth: 360 mm
Weight: 8.6 kg

技术参数

光源

光源:19颗*15W RGBA LED
LED寿命:20,000小时

光学系统

先进的光学系统,保证清晰大范围的光束洗色效果
高效变焦光学系统,比例1:6
变焦范围:10°-60°

控制程序

显示:液晶显示
协议:DMX512
控制通道:20/36CH
调光器:16位,0-100%

X/Y轴

X轴运动:540°
Y轴运动:270°
X/Y轴分辨率:16位
X/Y轴自动位置校正

电气控制

带电子自动量程的电源
输入电压范围:AC 100-240V, 50/60 Hz
功耗:360W

灯具规格

高度:380毫米
宽度:250毫米
深度:360毫米
重量:8.6公斤



KL-ML3610W

36颗*10W LED 调焦摇头染色灯

36PCS*10W LED Zoom Wash Moving Light

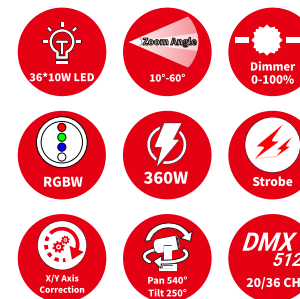

Technical Specifications

Light Source

Light source: 36PCS*10W RGBA LED
LED life expectancy: 20,000 hours

Optical System

The advanced optical system ensures a clear and large-range beam & wash effect
High-efficiency zoom optical system, ratio 1:6
Zoom range: 10°-60°

Control Program

Display: LCD display
Protocols: DMX512
Control channels: 20/36CH
Dimmer: 16-bit, 0-100%

PAN & TILT

Pan movement: 540°
Tilt movement: 270°
Pan/Tilt Resolution: 16-bit
Automatic Pan/Tilt position correction

Electrical Control

Power supply with electronic auto-ranging
Input voltage range: AC 100-240V, 50/60 Hz
Power consumption: 360W

Lighting Specification

Height: 380 mm
Width: 250 mm
Depth: 360 mm
Weight: 8.6 kg

技术参数

光源

光源:36颗*10W RGBA LED
LED寿命:20,000小时

光学系统

先进的光学系统,保证清晰大范围的光束洗色效果
高效变焦光学系统,比例1:6
变焦范围:10°-60°

控制程序

显示:液晶显示
协议:DMX512
控制通道:20/36CH
调光器:16位,0-100%

X/Y轴

X轴运动:540°
Y轴运动:270°
X/Y轴分辨率:16位
X/Y轴自动位置校正

电气控制

带电子自动量程的电源
输入电压范围:AC 100-240V, 50/60 Hz
功耗:360W

照明规格

高度:380毫米
宽度:250毫米
深度:360毫米
重量:8.6公斤

KL-ML740W

7颗*40W LED 调焦摇头染色灯
7PCS*40W LED Zoom Wash Moving Light



Technical Specifications

Power Supply: AC100-240V, 50/60Hz
 Light Source: 7*40W 4in1 LED
 Power consumption: 350W
 Beam angle: 5-50 degree
 Dimmer: 0-100% dimming
 Strobe: 0~20HZ
 Control mode: Standard DMX512, Automatic, and master/ slave mode
 Display: LCD display
 Housing: Flame-retardant plastic
 DMX channel: 12/17CH
 IP rate: IP20
 Data in/out: 3-pin XLR in-out
 Power in/out: powerCon in out
 N.W.: 7.5kg
 G.W.: 10kg

技术参数

电源: 100-240V, 50/60 Hz
 光源: 7颗40W 4in1 LED
 功耗: 350W
 光束角度: 5-50度
 调光器: 0-100%调光
 频闪: 0~20HZ
 控制模式: 标准DMX512、自动、主从模式
 显示: 液晶显示
 外壳: 阻燃塑料
 DMX通道: 12/17CH
 防护等级: IP20
 数据输入/输出: 3针XLR输入输出
 电源输入/输出: powerCon 输入输出
 净重: 7.5kg
 毛重: 10kg

KL-ML1210W

12颗*10W LED 调焦摇头染色灯
12PCS*10W LED Zoom Wash Moving Light



Technical Specifications

Power Supply: AC100-240V, 50-60Hz
 Power Consumption: 150W
 Light Source: 12*10W 4in1 RGBW High Brightness LED.
 Pan: 540 degree
 Tilt: 270 degree
 Control mode: DMX512, master-slave, and sound-activated controllable or auto operation
 DMX Channel: 15 DMX Channels
 Function: Strobe, Dimmer, Color Changing, Color Mixing
 Weight: 5KG

技术参数

电源: AC100-240V, 50-60Hz
 功耗: 150W
 光源: 12颗*10W 4合1 RGBW 高亮度 LED。
 X轴: 540度
 Y轴: 270度
 控制方式: DMX512、主从、声控可控或自动运行
 DMX通道: 15个DMX通道
 功能: 频闪、调光、变色、混色
 重量: 5KG

KL-ML712W

7颗*12W LED 调焦摇头染色灯
7PCS*12W LED Zoom Wash Moving Light



Technical Specifications

Power Supply: AC100-240V, 50-60Hz
 Power Consumption: 90W
 Light Source: 7pcs*12W 4in1 RGBW high-brightness LED
 Beam Angle: 8 degrees.
 Control mode: DMX512, master-slave, and sound activated controllable or auto-operation
 DMX Channel: 15 DMX Channels
 Function: Strobe, Dimmer, Color Changing, Color Mixing
 N.W: 5KG

技术参数

电源: AC100-240V, 50-60Hz
 功耗: 90W
 光源: 7颗*12W 4合1 RGBW高亮度LED
 光束角: 8度。
 控制方式: DMX512、主从、声控可控或自动运行
 DMX通道: 15个DMX通道
 功能: 频闪、调光、变色、混色
 净重: 5KG

KL-ML810P

8颗*10W LED 蜘蛛摇头灯
8PCS*10W LED Zoom Pixels Moving Light



Technical Specifications

Power Supply: AC100-240V 50/60Hz
 Light Source: 8PCS*10W RGBW 4IN1 LED
 Power Consumption: 120W
 Channel: 18CH
 Beam angle: 4.5 degree
 Control Mode: DMX512, Masterslave, Auto, Sound
 Tilt movement: 145 degrees
 Dimmer: 0-100% smooth dimming
 Strobe: Variable strobe speeds
 Inner package size: 470*310*215mm
 Outer package size: 650*485*240mm (2in1)
 N.W.: 6kg

技术参数

电源: AC100-240V 50/60Hz
 光源: 8PCS*10W RGBW 4IN1 LED
 功耗: 120W
 频道: 18CH
 光束角: 4.5度
 控制模式: DMX512、主从、自走、声控
 倾斜运动: 145度
 调光器: 0-100%平滑调光
 频闪: 可变频闪速度
 内包装尺寸: 470*310*215mm
 外包装尺寸: 650*485*240mm (2合1)
 净重: 6kg

KL-PAR5403-S

54颗*3W LED RGBW 帕灯

54PCS*3W LED RGBW PAR/CAN Light



Technical Specifications

Power Consumption: 180W
 Input Voltage: AC90-240V 50-60Hz
 Light Source: 54pcs RGBW LED
 Lamp Life: 80000-100,000 hours
 Control Mode: DMX512, Master-slave, Sound Activated, Stand-alone
 Beam Angle: 25° (45° optional)
 Signal Input: 3-core XLR input
 Signal Output: 3-core XLR output
 Operation Panel: LED Digital Display
 DMX Channel: 3/7 CH
 Dimmer: 0 ~ 100% linearly adjustable
 Strobe: 13 t/s (any colors)
 Housing Material: Die-cast aluminum housing
 Housing Color: Black
 Maximum Ambient Temperature: 40°
 Maximum Lamp Temperature: 60°
 Dimensions: 260*260*370mm
 Weight: 5kg

技术参数

功耗: 180W
 输入电压: AC90-240V 50-60Hz
 光源: 54颗RGBW LED
 灯泡寿命: 80000-100,000小时
 控制模式: DMX512、主从、声控、单机
 光束角度: 25° (45°可选)
 信号输入: 3芯XLR输入
 信号输出: 3芯XLR输出
 操作面板: LED数字显示
 DMX通道: 3/7 CH
 调光器: 0~100%线性可调
 频闪: 13 t/s (任何颜色)
 外壳材质: 压铸铝外壳
 外壳颜色: 黑色
 最高环境温度: 40°
 最高灯温: 60°
 尺寸: 260*260*370mm
 重量: 5公斤

KL-PAR5403

54颗*3W LED 3合1 帕灯

54PCS*3W LED 3in1 PAR/CAN Light



Technical Specifications

Power Consumption: 180W
 Input Voltage: AC90-240V 50-60Hz
 Light Source: 54pcs 3in1 RGB LED
 Lamp Life: 80000-100,000 hours
 Control Mode: DMX512, Master-slave, Sound Activated, Stand-alone
 Beam Angle: 25° (45° optional)
 Signal Input: 3-core XLR input
 Signal Output: 3-core XLR output
 Operation Panel: LED Digital Display
 DMX Channel: 3/7 CH
 Dimmer: 0 ~ 100% linearly adjustable
 Strobe: 13 t/s (any colors)
 Housing Material: Die-cast aluminum housing
 Housing Color: Black
 Maximum Ambient Temperature: 40°
 Maximum Lamp Temperature: 60°
 Dimensions: 260*260*370mm
 Weight: 5kg

技术参数

功耗: 180W
 输入电压: AC90-240V 50-60Hz
 光源: 54颗三合一RGB LED
 灯泡寿命: 80000-100,000小时
 控制模式: DMX512、主从、声控、单机
 光束角度: 25° (45°可选)
 信号输入: 3芯XLR输入
 信号输出: 3芯XLR输出
 操作面板: LED数字显示
 DMX通道: 3/7 CH
 调光器: 0~100%线性可调
 频闪: 13 t/s (任何颜色)
 外壳材质: 压铸铝外壳
 外壳颜色: 黑色
 最高环境温度: 40°
 最高灯温: 60°
 尺寸: 260*260*370mm
 重量: 5公斤

KL-PAR1810-1

18颗*10W LED 帕灯

18PCS*10W LED PAR/CAN Light



Technical Specifications

Power input: AC100~240V 50/60Hz
 Maximum power: 270W
 Beam divergence angle: 25° (15°/45° optional)
 Light source: 18*15W RGBW
 Control protocol: DMX512
 DMX channel: 4/8 channel
 Control mode: DMX, automatic operation
 Operation mode: master-slave synchronous, stand-alone self-propelled, voice control signal input/output: 3-pin Carron seat
 Lighting size: L1000*W180*H18mm
 Housing material: Die-cast aluminum
 Weight: 5.5kgs
 Gross weight: 6kgs

技术参数

输入电源: AC100~240V 50/60Hz
 最大功率: 270W
 光束发散角: 25° (15°/45°可选)
 光源: 18*15W RGBW
 控制协议: DMX512
 DMX通道: 4/8通道
 控制方式: DMX、自动运行
 运行方式: 主从同步、单机自走、声控信号
 输入/输出: 3针卡伦座
 灯具尺寸: L1000*W180*H18mm
 外壳材质: 压铸铝
 重量: 5.5公斤
 毛重: 6公斤

KL-PAR1810-2

18颗*10W LED 帕灯

18PCS*10W LED PAR/CAN Light



Technical Specifications

Power: 180W
 Voltage: AC90-240V 50/60Hz
 LED life expectancy: 50,000 hours
 Running mode: DMX512/self-propelled/voice-activated/master-slave
 Handle selection: single/double
 Signal line: 3-core XRL
 Dimming: 0-100%
 Color temperature: 7500K
 Color rendering: red, green, blue, white, mixed colors
 IP value: IP20
 Net weight: 4.55 kg
 Gross weight: 5.55 kg
 Packing size (1 pack 1): 30*30*36 cm
 Flight case size (1 pack of 8): 112*57*60cm/65.4kg

技术参数

功率: 180W
 电压: AC90-240V 50/60Hz
 LED预期使用寿命: 50,000小时
 运行模式: DMX512/自走/声控/主从
 提手选择: 单/双
 信号线: 3芯XRL
 调光: 0-100%
 色温: 7500K
 颜色: 红, 绿, 蓝, 白, 混色
 IP值: IP20
 净重: 4.55千克
 毛重: 5.55千克
 包装尺寸(1装1): 30*30*36厘米
 航空箱尺寸(1装8): 112*57*60厘米/65.4千克

KL-PAR20-UV 20W COB紫光帕灯 20W COB UV PAR/CAN Light



Technical Specifications

Power supply: AC100-240V, 50-60Hz
Power Consumption: 20W
Light source: purple high-brightness LED
Lighting angle: 6 degrees
Control mode: DMX512, master-slave and voice control or automatic operation
DMX channel: 11ch/15ch
Cooling system: low noise, efficient fan cooling system
Net weight: 2KG
Gross weight: 3KG

技术参数

电源:AC100-240V, 50-60HZ
功耗:20W
光源:紫色高亮度LED
发光角度:6度
控制方式:DMX512、主从、声控或自动运行
DMX通道:11通道/15通道
冷却系统:低噪音、高效风扇冷却系统
净重:2KG
毛重:3KG

KL-FL4015P 40颗防水投光灯 40 Waterproof Flood Light



Technical Specifications

Power supply: AC110-240V, 50/60HZ
Power: 600W
Lights: 40PCS*15W RGBW 4in1
Light life: 50000 hours
Dimmer: 0-100%
Strobe: 1-20 times/second
Beam Angle: 40°/25°/15°optional
Number LCD
Operation mode: Standard DMX512, master-slave, self-propelled, voice control
DMX channel: 4/8/12CH
Cooling system: natural convection heat transfer
Working environment temperature: -20P-40 pair
Effect distance: 40m
IP rating: IP65

技术参数

电源:AC110-240V, 50/60HZ
功率:600W
灯珠:40PCS*15W RGBW 4in1
光源寿命:50000小时
调光器:0-100%
频闪:1-20次/秒
光束角度:40°/25°/15°可选
数字液晶显示
操作模式:标准
DMX512、主从、自走、声控
DMX通道:4/8/12CH
冷却系统:自然对流换热
工作环境
温度:-20P-40对
作用距离:40m
防护等级:IP65

KL-PAR36P 36W LED 防水帕灯 36PCS LED Waterproof PAR/CAN Light



Technical Specifications

Light source
Light source: 9 x 15W RGBW U LED
LED life expectancy: 20000 hours
Optical system
The advanced optical system ensures a clear and large-range beam & wash effect
Beam Angle: 30°
Control and Program
4-buttons
Display: LED display
Protocols: DMX, Master/Slave
DMX Protocol modes: 3
Control channels: 5, 9CH
Electrical and Connectors
Power supply with electronic auto-ranging
Input voltage range: AC 100-240 V, 50/60 Hz
Power consumption: 185 W
Power cord out
Data in/out: 3-pin XLR socket
The fuse standard is 2A/250V
Lighting Specification
Height: 240 mm
Width: 130mm
Depth: 250 mm
Weight: 3.8kg

技术参数

光源
光源:9 x 15W RGBW U LED
LED寿命:20000小时
光学系统
先进的光学系统,保证清晰大范围的光束染色效果
光束角:30°
控制与编程
4个按钮
显示:LED显示
协议:DMX、主/从
DMX协议模式:3
控制通道:5,9CH
电气和连接器
带电子自动量程的电源
输入电压范围:AC 100-240 V, 50/60 Hz
功耗:185W
电源线输出
数据输入/输出:3针XLR插座
保险丝标准为2A/250V
照明规格
高度:240毫米
宽度:130毫米
深度:250毫米
重量:3.8公斤

KL-LS1000 1000W 频闪灯 1000W Strobe Light



Technical Specifications

Voltage: AC100-240V, 50/60HZ
Power: 240W
Lamp beads: 960pcs 5050 tri-color LED lamp beads
Control mode: DMX512, self-propelled, master-slave, voice control, with RDM function.
Channel: CH03, CH09, CH24
Dimming: 32bit 0~100% linear dimming
Features: 8-segment horse racing +Wash + flashing
Working temperature: -30 degrees to 50 degrees
Strobe frequency: 1~30HZ
Appearance: metal, black
Connection mode: DMX512
Signal input/output: 3-pin XLR plug/seat
Power input/output: Neutrik plug/seat
IP rating: IP20

技术参数

电压:AC100-240V, 50/60HZ
功率:240W
灯珠:960颗5050三色LED灯珠
控制方式:DMX512、自走、主从、声控、带RDM功能。
通道:CH03、CH09、CH24
调光:32bit 0~100%线性调光
特点:8段跑马+洗车+闪光
工作温度:-30度至50度
频闪频率:1~30HZ
外观:金属、黑色
连接方式:DMX512
信号输入/输出:3针XLR插头/座
电源输入/输出:Neutrik插头/座
防护等级:IP20

KL-PAR5403P-S

54颗*3W LED RGBW 防水帕灯

54PCS*3W LED RGBW Waterproof PAR/CAN Light



Technical Specifications

Light Source
Light source: 54PCS*3W RGBW LED
LED life expectancy: 20000 hours
Optical system
The advanced optical system ensures clear and large-range beam & wash effect
Beam Angle: 19°
Control and Program
4-buttons
Display: LED display
Protocols: DMX, Master/Slav, RDM
DMX Protocol: DMX512
Control channels: 4CH/8CH
Upgrade the firmware via the DMX link
Electrical and Connectors
Power supply with electronic auto-ranging
Input voltage range: AC 100-240 V, 50/60 Hz
Power consumption: 170W
Power cord out
Data in/out: 3-pin XLR socket
Lighting Specifications
Height: 400 mm
Width: 300 mm
Depth: 300 mm
Weight: 5kg

技术参数

光源
光源: 54颗*3W RGBW LED
LED寿命: 20000小时
光学系统
先进的光学系统确保清晰大范围的光束染色效果
光束角: 19°
控制与编程
4个按钮
显示: LED显示
协议: DMX、主/从、RDM
DMX协议: DMX512
控制通道: 4CH/8CH
通过DMX链接升级固件
电气和连接器
带电子自动量程的电源
输入电压范围: AC 100-240 V, 50/60 Hz
功耗: 170W
电源线输出
数据输入/输出: 3针XLR插座
照明规格
高度: 400毫米
宽度: 300毫米
深度: 300毫米
重量: 5公斤

KL-PAR54P

54颗*3W LED 3合1 防水帕灯

54PCS*3W LED 3in1 Waterproof PAR/CAN Light



Technical Specifications

Light Source
Light source: 54PCS*3W RGB 3in1 LED
LED life expectancy: 20000 hours
Optical system
The advanced optical system ensures clear and large-range beam & wash effect
Beam Angle: 19°
Control and Program
4-buttons
Display: LED display
Protocols: DMX, Master/Slav, RDM
DMX Protocol: DMX512
Control channels: 4CH/8CH
Upgrade the firmware via the DMX link
Electrical and Connectors
Power supply with electronic auto-ranging
Input voltage range: AC 100-240 V, 50/60 Hz
Power consumption: 170W
Power cord out
Data in/out: 3-pin XLR socket
Lighting Specifications
Height: 400 mm
Width: 300 mm
Depth: 300 mm
Weight: 5kg

技术参数

光源
光源: 54PCS*3W RGB 3合1 LED
LED寿命: 20000小时
光学系统
先进的光学系统确保清晰大范围的光束染色效果
光束角: 19°
控制与编程
4个按钮
显示: LED显示
协议: DMX、主/从、RDM
DMX协议: DMX512
控制通道: 4CH/8CH
通过DMX链接升级固件
电气和连接器
带电子自动量程的电源
输入电压范围: AC 100-240 V, 50/60 Hz
功耗: 170W
电源线输出
数据输入/输出: 3针XLR插座
照明规格
高度: 400毫米
宽度: 300毫米
深度: 300毫米
重量: 5公斤

KL-PAR1810P-1

18颗*10W LED 防水帕灯

18PCS*10W LED Waterproof PAR/CAN Light



Technical Specifications

Light source
Light source: 18PCS*10W RGBW LED
LED life expectancy: 20000 hours
Optical system
The advanced optical system to ensure clear and large-range beam & wash effect
Beam Angle: 19°
Control and Program
4-buttons
Display: LED display
Protocols: DMX, Master/Slav, RDM
DMX Protocol modes: 3
Control channels: 4,8
Upgrade the firmware via the DMX link
Electrical and Connectors
Power supply with electronic auto-ranging
Input voltage range: AC 100-240 V, 50/60 Hz
Power consumption: 180W
Power cord out
Data in/out: 3-pin XLR socket
Lighting Specification
Height: 300 mm
Width: 300 mm
Depth: 210 mm
Weight: 4.5kg

技术参数

光源
光源: 18PCS*10W RGBW LED
LED寿命: 20000小时
光学系统
先进的光学系统, 保证清晰大范围的光束染色效果
光束角: 19°
控制与编程
4个按钮
显示: LED显示
协议: DMX、主/从、RDM
DMX协议模式: 3
控制通道: 4,8
通过DMX链接升级固件
电气和连接器
带电子自动量程的电源
输入电压范围: AC 100-240 V, 50/60 Hz
功耗: 180W
电源线输出
数据输入/输出: 3针XLR插座
照明规格
高度: 300毫米
宽度: 300毫米
深度: 210毫米
重量: 4.5公斤

KL-PAR1810P-L

18颗*10W LED 防水帕灯

18PCS*10W LED Waterproof PAR/CAN Light



Technical Specifications

Light source
Light source: 18PCS*10W RGBW LED
LED life expectancy: 20000 hours
Optical system
The advanced optical system to ensure clear and large-range beam & wash effect
Beam Angle: 19°
Control and Program
4-buttons
Display: LED display
Protocols: DMX, Master/Slav, RDM
DMX Protocol modes: 3
Control channels: 4,8
Upgrade the firmware via the DMX link
Electrical and Connectors
Power supply with electronic auto-ranging
Input voltage range: AC 100-240 V, 50/60 Hz
Power consumption: 180W
Power cord out
Data in/out: 3-pin XLR socket
Lighting Specification
Height: 300 mm
Width: 300 mm
Depth: 450 mm
Weight: 6.5kg

技术参数

光源
光源: 18PCS*10W RGBW LED
LED寿命: 20000小时
光学系统
先进的光学系统, 保证清晰大范围的光束染色效果
光束角: 19°
控制与编程
4个按钮
显示: LED显示
协议: DMX、主/从、RDM
DMX协议模式: 3
控制通道: 4,8
通过DMX链接升级固件
电气和连接器
带电子自动量程的电源
输入电压范围: AC 100-240 V, 50/60 Hz
功耗: 180W
电源线输出
数据输入/输出: 3针XLR插座
照明规格
高度: 300毫米
宽度: 300毫米
深度: 450毫米
重量: 6.5公斤

KL-PAR18P-2
18PCS LED 防水帕灯
18PCS LED Waterproof PAR/CAN Light



Technical Specifications	技术参数
Power supply: AC100-240V, 50-60Hz	电源:AC100-240V, 50-60Hz
Power Consumption: 200W	功耗:200W
Light source: 18PCS * 10W high brightness LED	光源:18PCS*10W高亮度LED
Bulb life: 60,000-100,000 hours	灯泡寿命:60,000-100,000小时
Color: RGBW color mixing can exceed 16.7 million colors	颜色:RGBW混色可超过1670万种颜色
Control mode: DMX512, master/slave, automatic, voice control	控制模式:DMX512、主从、自动、声控
Control channel: 8CHS	控制通道:8CHS
Protection class: Ip65	防护等级:IP65
Size: 300*300*200mm	尺寸:300*300*200mm
Net weight: 4.5 kg	净重:4.5公斤
Gross weight: 5.1 kg	毛重:5.1公斤

KL-PAR12P
12PCS LED 防水帕灯
12PCS LED Waterproof PAR/CAN Light



Technical Specifications	技术参数
Power supply: AC100-240V, 50-60Hz	电源:AC100-240V, 50-60Hz
Power Consumption: 130W	功耗:130W
Light source: 12PCS * 10W RGBWA high brightness LED	光源:12PCS*10W RGBWA高亮度LED
Bulb life: 60,000-100,000 hours	灯泡寿命:60,000-100,000小时
Color: RGBWA color mixing can exceed 16.7 million colors	颜色:RGBWA混色可超过1670万种颜色
Control mode: DMX512, master/slave, automatic, voice control	控制模式:DMX512、主从、自动、声控
Control channel: 9CHS	控制通道:9CHS
Protection class: IP 65	防护等级:IP 65
Size: 230*230*330mm	尺寸:230*230*330mm
Net weight: 6.5 kg	净重:6.5公斤

KL-PAR09P
9PCS LED 防水帕灯
9PCS LED Waterproof PAR/CAN Light



Technical Specifications	技术参数
Power supply: AC100-240V, 50-60Hz	电源:AC100-240V, 50-60Hz
Power Consumption: 120W	功耗:120W
Light source: 9PCS * 12W RGBWA high brightness LED	光源:9PCS*12W RGBWA高亮度LED
Bulb life: 60,000-100,000 hours	灯泡寿命:60,000-100,000小时
Color: RGBWA color mixing can exceed 16.7 million colors	颜色:RGBWA混色可超过1670万种颜色
Control mode: DMX512, master/slave, automatic, voice control	控制模式:DMX512、主从、自动、声控
Control channel: 9CHS	控制通道:9CHS
Protection class: IP 65	防护等级:IP 65
Size: 230*230*300mm	尺寸:230*230*300mm
Net weight: 4.7 kg	净重:4.7公斤

KL-PAR07P
7PCS LED 防水帕灯
7PCS LED Waterproof PAR/CAN Light



Technical Specifications	技术参数
Power supply: AC100-240V, 50-60Hz	电源:AC100-240V, 50-60Hz
Power Consumption: 80W	功耗:80W
Light source: 7PCS * 10W RGBWA high brightness LED	光源:7PCS*10W RGBWA高亮度LED
Bulb life: 60,000-100,000 hours	灯泡寿命:60,000-100,000小时
Color: RGBWA color mixing can exceed 16.7 million colors	颜色:RGBWA混色可超过1670万种颜色
Control mode: DMX512, master/slave, automatic, voice control	控制模式:DMX512、主从、自动、声控
Control channel: 9CHS	控制通道:9CHS
Protection class: IP 65	防护等级:IP 65
Size: 230*230*300mm	尺寸:230*230*300mm
Net weight: 3.5 kg	净重:3.5公斤



KL-LPC200P

200W LED 平凸透镜防水聚光灯

200W LED Plano-Convex Lens Waterproof Spotlight



KL-LPS200P

200W LED 柔光透镜防水聚光灯

200W LED Waterproof Spotlight



Technical Specifications

Light Source
Light source: 200W COB
LED life: 20,000 hours

Optical System
Dimming: 0%-100% linear dimming
Color temperature: 3200K-6500K

Control Program
Control mode: standard DMX512, 3-core interface, self-propelled, master-slave

Function Effect
Color: 3200K/5600K/WC/RGBW optional
Focus: Electric focus
Focusing angle: 10° -60°

electrical control
Input voltage range: AC 100-240V, 50/60 Hz
Power supply: 220W

Lighting specification
Height: 180mm
Width: 264mm
Length: 410mm
Weight: 7kg
Protection class: IP65

技术参数

光源
光源: 200W COB
LED寿命: 20,000小时

光学系统
调光: 0%-100%线性调光
色温: 3200K-6500K

控制程序
控制方式: 标准DMX512、3芯接口、自走、主从

功能效果
颜色: 3200K/5600K/WC/RGBW可选
调焦: 电动调焦
聚焦角度: 10°-60°

电气控制
输入电压范围: AC 100-240V, 50/60 Hz
电源: 220W

照明规格
高度: 180毫米
宽度: 264毫米
长度: 410毫米
重量: 7公斤
防护等级: IP65

Technical Specifications

Light Source
Light source: 200W COB
Lamp bead life: more than 50,000 hours

Effect
Strobe: Electronic strobe, 0-30 times/second
Effect: 0-100% smooth linear dimming, no jitter; refresh frequency 20500Hz. Using a stable constant current drive and power supply, suitable for video shooting
Illumination transition balance, no speckle, no visible relative dark area

Control Program
Channel: 2/3/5 CH
Mode: DMX512, self-propelled, master-slave, Central control
Operation interface: LED digital tube display
Control mode: self-propelled, voice control, master-slave, DMX512

Electrical Control
Rated voltage: AC100-250V, 50-60Hz
Maximum power consumption: 200W
Signal: Three-core signal input and output
Power supply: PowerCon in/out

Lighting Specifications
Height: 200mm
Width: 235mm
Length: 400mm
Weight: 8kg
Protection class: IP65

技术参数

光源
光源: 200W COB
灯珠寿命: 大于50000小时

影响
频闪: 电子频闪, 0-30次/秒
效果: 0-100%平滑线性调光, 无抖动; 刷新频率 20500Hz。采用稳定的恒流驱动和电源, 适合视频拍摄
照度过渡平衡, 无散斑, 无可见相对暗区

控制程序
通道: 2/3/5通道
模式: DMX512、自走、主从、中控
操作界面: LED数码管显示
控制方式: 自走、声控、主从、DMX512

电气控制
额定电压: AC100-250V, 50-60Hz
最大功耗: 200W
信号: 三芯信号输入输出
电源: PowerCon 输入/输出

照明规格
高度: 200毫米
宽度: 235毫米
长度: 400毫米
重量: 8公斤
防护等级: IP65

KL-LC450P
200W LED 4眼防水面光灯
200W LED Waterproof Spotlight



Technical Specifications	技术参数
Input voltage: AC100-240V 50/60HZ	输入电压:AC100-240V 50/60HZ
Power: 220W	功率: 220W
Light source: 200W COB	光源:200W COB
Color: 3200K/5600K/WC/RGBW optional	颜色:3200K/5600K/WC/RGBW 可选
Color temperature: 3200K-6500K	色温: 3200K-6500K
Lamp bead life: >200000h	灯珠寿命:>200000h
Dimming: 0%-100% linear dimming	调光:0%-100%线性调光
Focus: Electric focus	调焦: 电动调焦
Focusing angle: 10° -60°	聚焦角度:10° -60°
Control mode: standard DMX512, 3-core interface, self-propelled, master-slave	控制方式: 标准DMX512、3芯接口、自走、主从
Protection class: IP65	防护等级:IP65
Product size: 410*264*180mm	产品尺寸:410*264*180mm
Net weight: 7kg	净重: 7kg

KL-LPC300P
300W LED 平凸透镜防水聚光灯
300W LED Plano-Convex Lens Waterproof Spotligh



Technical Specifications	技术参数
Input voltage: AC100-240V 50/60HZ	输入电压:AC100-240V 50/60HZ
Power: 300W	功率: 300W
Light source: 300W COB	光源: 300W COB
Color: 3200K/5600K/WC/RGBW optional	颜色: 3200K/5600K/WC/RGBW 可选
Color temperature: 3200K-6500K	色温: 3200K-6500K
Lamp life: 20000h	灯珠寿命: 20000h
Dimming: 0%-100% linear dimming	调光:0%-100%线性调光
Focus: electric focus	调焦: 电动调焦
Focusing angle: 15° -60°	调焦角度:15° -60°
Control mode: standard DMX512, 3-core interface, self-propelled, master-slave	控制模式: 标准DMX512、3芯接口、自走、主从
Protection class: IP65	防护等级:IP65
Product size: 410*264*180mm	产品尺寸:410*264*180mm
Net weight: 7kg	净重: 7kg

KL-LPC200P
200W LED 平凸透镜防水聚光灯
200W LED Plano-Convex Lens Waterproof Spotlight



Technical Specifications	技术参数
Input voltage: AC100-240V 50/60HZ	输入电压:AC100-240V 50/60HZ
Power: 300W	功率: 300W
Light source: 300W COB	光源: 300W COB
Color: 3200K/5600K/WC/RGBW optional	颜色: 3200K/5600K/WC/RGBW 可选
Color temperature: 3200K-6500K	色温: 3200K-6500K
Lamp life: 20000h	灯珠寿命: 20000h
Dimming: 0%-100% linear dimming	调光:0%-100%线性调光
Focus: electric focus	调焦: 电动调焦
Focusing angle: 15° -60°	调焦角度:15° -60°
Control mode: standard DMX512, 3-core interface, self-propelled, master-slave	控制模式: 标准DMX512、3芯接口、自走、主从
Protection class: IP65	防护等级:IP65
Product size: 410*264*180mm	产品尺寸:410*264*180mm
Net weight: 7kg	净重: 7kg

KL-LPF150P
150W LED 螺纹透镜防水聚光灯
150W LED Waterproof FresnelSpotlight



Technical Specifications	技术参数
Rated voltage: AC100-250V, 50-60Hz	额定电压:AC100-250V, 50-60Hz
Maximum power consumption: 150W	最大功耗:150W
Light source: 150W COB	光源:150W COB
Lamp bead life: more than 50,000 hours	灯珠寿命: 大于50000小时
Channel: 6CH	频道:6CH
Mode: DMX512, self-propelled, master-slave, central control	模式:DMX512、自走、主从、中控
Operation interface: LED digital tube display	操作界面:LED数码管显示
Control mode: self-propelled, voice control, master-slave, DMX512	控制方式: 自走、声控、主从、DMX512
Strobe: Electronic strobe, 0-30 times/second	频闪: 电子频闪, 0-30次/秒
Signal: Three-core signal input and output	信号: 三芯信号输入输出
Power supply: PowerCon in/output	电源:PowerCon 输入/输出
Effect: 0-100% smooth linear dimming, no jitter; refresh frequency 20500Hz.	效果:0-100%平滑线性调光, 无抖动; 刷新频率20500Hz。
Using a stable constant current drive and power supply, suitable for video shooting	采用稳定的恒流驱动和电源, 适合视频拍摄
Illumination transition balance, no speckle, no visible relative dark	照度过渡平衡, 无散斑, 无可见相对暗



KL-FS350 350W 追光灯 350W Follow Spotlight

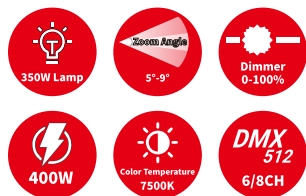

Technical Specifications

Light Source
Light source: 350W
LED life: 2000 hours

Optical System
Linear: 0~100% dimming
Aperture: 5~100% dimmer
Color temperature: 7500k

Control Program
Focus: manual focus
Temperature control: forced air cooling
Manual control panel or DMX control

Function Effect
Adjustable color temperature: 5800K, 4600k, 3200k
Projection distance: 300 meters
Color: 5 colors + white light (red, green, blue, yellow and orange)

electrical control
Input voltage range: AC 100-240V, 50/60 Hz
Power supply: 400W

Lighting specification
Height: 280mm
Width: 220mm
Length: 640mm
Weight: 15kg
Protection level: IP20, overheat and overvoltage protection

技术参数

光源
光源: 350W
LED寿命: 2000小时

光学系统
线性: 0~100%调光
光圈: 5~100%调光
色温: 7500k

控制程序
焦点: 手动对焦
温度控制: 强制风冷
手动控制面板或DMX控制

功能效果
色温可调: 5800K, 4600k, 3200k
投光距离: 300米
色彩: 5颜色 + 白光 (红绿蓝黄橙)

电气控制
输入电压范围: AC 100-240V, 50/60 Hz
电源: 400W

灯具规格
高度: 280毫米
宽度: 220毫米
长度: 640毫米
重量: 15公斤
保护等级: IP20, 过热和过压保护



KL-FS470 470W 追光灯 470W Follow Spotlight



Technical Specifications

Light Source
Light source: 470W
LED life: 2000 hours

Optical System
Beam angle: 5-9°
Color temperature: Built-in 7500K, 6500K, 4500K, 3200K

Control Program
Control mode: manual control panel, DMX 512
Channel: 4CH
Dimmer: double chip dimming
Aperture: linear zoom in and zoom out

Electrical Control
Voltage: AC 100-240V, 50/60Hz
Power supply: 550W

Lighting Specifications
Height: 310mm
Width: 270mm
Length: 650mm
Shell material: steel + aluminum
Weight: 38 kg (+ flight case)

技术参数

光源
光源: 470W
LED寿命: 2000小时

光学系统
光束角度: 5-9°
色温: 内置7500K □ 6500K □ 4500K □ 3200K

控制程序
控制方式: 手动控制面板, DMX 512
通道: 4CH
调光器: 双片调光
光圈: 线性放大和缩小

电气控制
电压: AC 100-240V, 50/60 Hz
电源: 550W

照明规格
高度: 310毫米
宽度: 270毫米
长度: 650毫米
外壳材质: 钢铁+铝
重量: 38公斤 (+航空箱)



KL-LP200H 200W LED 成像灯-高显指 200W LED Profile Spotlight

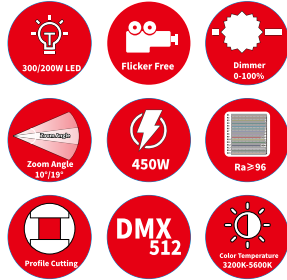

Technical Specifications

The LED imaging light adopts high-efficiency and energy-saving 300W/200W high-power LED light source to replace the traditional halogen light source. Its high brightness, low flicker, environmental protection and non-radiation characteristics can effectively reduce the damage to the person or objects being illuminated. It is also the metal halide lamp and fluorescent lamp. incomparable. The unique, novel and beautiful lamp body shell is made of allaluminum alloy, and the professional and unique heat conduction design makes the lamp have good heat dissipation performance, which can effectively reduce the light decay and prolong the service life

light source
300/200W LED
Color temperature: 3200K/5600K
Light Source: RGBW LED
Color rendering index: Ra ≥ 95
optical system
10°/19° fixed focus lens optional
operate
International standard DMX control protocol
Self-propelled, custom program
Precise linear dimming (0-100%)
electrical characteristics
Rated voltage: AC100-240V.56-60HZ
Rated power: 450W
Power factor: PF0.92 or more (full load)
Thermal performance
Powerful heat dissipation fan multi-blade pull aluminum convection heat transfer lamp body shell
heat dissipation
Exterior
Rear compartment weight: 9.8kg
Housing: die-cast aluminum

技术参数

LED成像灯采用高效节能的300W/200W大功率LED光源替代传统的卤素光源,其高亮度、低频闪、环保无辐射的特性可有效减少对被照人或物品的侵害,亦是金卤灯、荧光灯所无法比拟的。独特新颖美观的灯体外壳由全铝合金组成,以及专业独特的导热设计使灯具具有良好的散热性能,可有效减小光衰,延长使用寿命

光源
300/200W LED
色温:3200K/5600K
光源:RGBW LED
显色指数:Ra ≥ 95
光学系统
10°/19°定焦镜头可选
操作
国际标准DMX控制协议
自走、自定义程序
精确线性调光(0-100%)
电气特征
额定电压:AC100-240V.56-60HZ
额定功率:450W
功率因素:PF0.92以上(满载)
散热性能
强力散热风扇多叶片拉铝对流散热灯体外壳散热
外观
后仓重量:9.8kg
外壳:压铸铝



KL-LF200H 200W LED 螺纹聚光灯-高显指 200W LED Fresnel Spotlight



Technical Specifications

light source
RGBW LED
Rated voltage: AC100-240V.56-60HZ
Rated power: 250W
Color temperature: (3200±150K/5600±150K)
Color rendering index: Ra ≥ 95
optical system
Fresnel lens
operate
Control panel: LCD liquid crystal display + four buttons
Channel mode: 2CH/3CH/8CH
Light angle: 15-60 degrees, manual zoom, electronic zoom integrated
Control mode: DMX512 control/manual mode
Self-propelled, custom program
Precise linear dimming (0-100%)
Waterproof grade: Ip20
electrical characteristics
Power factor: PF0.92 or more (full load)
Heat dissipation performance: copper tube radiator
main feature
Over-temperature protection: built-in temperature protection sensor, through automatic adjustment of lamp power for overtemperature
protection
Exterior
Shell: aluminum alloy
Colour: Black
Net weight/gross weight: 9.5kg
Light body size: 455x265x292mm

技术参数

光源
RGBW LED
额定电压:AC100-240V.56-60HZ
额定功率:250W
色温:(3200±150K/5600±150K)
显色指数:Ra ≥ 95
光学系统
菲涅尔镜片
操作
控制面板:LCD液晶显示屏+四按键
通道模式:2CH/3CH/8CH
出光角度:15-60度,手动变焦、电子变焦一体
控制模式:DMX512控制/手动模式
自走、自定义程序
精确线性调光(0-100%)
防水等级:IP20
电气特征
功率因素:PF0.92以上(满载)
散热性能:铜管散热器
主要特点
过温保护:内置温度保护传感器,通过自动调节灯具功率来进行过温保护
外观
外壳:铝合金
颜色:黑色
净重/毛重:9.5kg
灯体尺寸:455x265x292mm



KL-BL4100 4眼观众灯 4 Eye Blinder Light

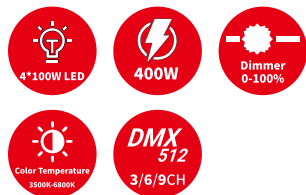

KL-BL4100P-2 4眼防水观众灯 4 Eyes Waterproof Blinder Light

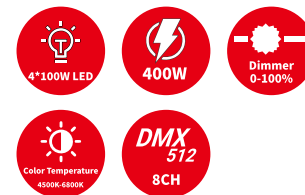

Technical Specifications

Light Source
Light Source: 4pcs*100W C/W LED
LED Lifespan: 50,000hours

Optical System
Dimmer: 0-100% linear dimming,
separate strobe

Control Program
Control Mode: DMX512/Auto/Sound
Active/Master-slave
DMX Channel:2/3/6/9 channels

Function Effect
Strobe: Electronic strobe, 0-30
times/second

Electrical Control
Power: 400W
Input Voltage: AC100—240V,50/60HZ

Lighting Specification
Height: 395mm
Width: 370mm
Length: 220mm
Weight: 11kg

技术参数

光源
光源:4颗*100W C/W LED
LED 寿命:50,000 小时

光学系统
调光器:0-100%线性调光, 独立频闪

控制程序
控制模式:DMX512/自走/声控/主从
DMX通道:2/3/6/9通道

功能效果
频闪:电子频闪,0-30次/秒

电气控制
功率:400W
输入电压:AC100—240V,50/60HZ

照明规格
高度:395毫米
宽度:370毫米
长度:220毫米
重量:11公斤

Technical Specifications

Light Source
Light source: 4PCS*100W COB
Lamp bead life: 50,000 hours

Optical System
Effect: 0-100% smooth linear dimming, no jitter;
refresh frequency 20500Hz.
Illumination transition is balanced, with no
speckle, no visible relative dark area

Control Program
Channel: 8ch
Mode: DMX512, self-propelled, master-slave,
Central control
Operation interface: LED digital tube display
Control mode: self-propelled, voice control,
master-slave, DMX512

Function Effect
Strobe: Electronic strobe, 0-30 times/second

Electrical Control
Signal: Three-core signal input and output
Power supply: PowerCon in/out
Using a stable constant current drive and power
supply, suitable for video shooting

Lighting Specification
Height: 400mm
Width: 250mm
Length: 410mm
Weight: 12kg

技术参数

光源
光源:4PCS*100W COB
灯珠寿命:50000小时

光学系统
效果:0-100%平滑线性调光, 无抖动; 刷新频率
20500Hz。
光照过渡均衡, 无散斑, 无可见相对暗区

控制程序
通道:8通道
模式:DMX512、自走、主从、中控
操作界面:LED数码管显示
控制方式:自走、声控、主从、DMX512

功能效果
频闪:电子频闪,0-30次/秒

电气控制
信号:三芯信号输入输出
电源:PowerCon 输入/输出
采用稳定的恒流驱动和电源, 适合视频拍摄

照明规格
高度:400毫米
宽度:250毫米
长度:410毫米
重量:12公斤

KL-BL2100

2眼观众灯 2 Eye Blinder Light



Technical Specifications

Power Consumption: 250W
Input Voltage: AC100-240V, 50/60HZ
Light Source: 2pcs*100W C/W LED
Led lifespan: 50000hours
Control Mode: DMX512/Auto/Sound Active/Master-slave
DMX Channel: 2/3/5channels
Dimmer: 0-100% linear dimming, separate strobe
Working temperature: -20°C to 40°C
Display: LCD display
IP Rating: Ip20
N.W: 5kg
Packing size: 370*290*240mm

技术参数

功耗: 450W
输入电压: AC90-240V, 50/60HZ
光源: 18颗*15W 3in1 LED
LED寿命: 50000~100000小时
LED PWM调光频率: >400Hz
DMX通道: 2/3/5/8/42/44CH
控制模式: DMX512/自走/声控/主控
功能效果: 调光/频闪/混色/渐变/单控
冷却方式: 自然对流
防护等级: IP 65
频闪: 1-18次/秒
发光颜色: R G B W混合
光束角度: 15-45° (可选)
产品尺寸: 100*22*10mm
重量: 8.15KG

KL-BL2100P-2

2眼防水观众灯 2 Eyes Waterproof Blinder Light



Technical Specifications

Light source: 2PCS*100W COB
Lamp bead life: more than 50,000 hours
Channel: 8ch
Mode: DMX512, self-propelled, master-slave, central control
Operation interface: LED digital tube display
Control mode: self-propelled, voice control, master-slave, DMX512
Strobe: Electronic strobe, 0-30 times/second
Signal: Three-core signal input and output
Power supply: PowerCon in/out
Effect: 0-100% smooth linear dimming, no jitter; refresh frequency 20500Hz.
Using a stable constant current drive and power supply, suitable for video shooting
Illumination transition is balanced, with no speckle, no visible relative dark area

技术参数

光源: 2PCS*100W COB
灯珠寿命: 大于50000小时
通道: 8通道
模式: DMX512、自走、主从、中控
操作界面: LED数码管显示
控制方式: 自走、声控、主从、DMX512
频闪: 电子频闪, 0-30次/秒
信号: 三芯信号输入/输出
电源: PowerCon 输入/输出
效果: 0-100%平滑线性调光, 无抖动; 刷新频率20500Hz。
采用稳定的恒流驱动和电源, 适合视频拍摄
光照过渡均衡, 无散斑, 无可见相对暗区

KL-BL4100P-1

4眼防水观众灯 4 Eyes Waterproof Blinder Light



Technical Specifications

Rated voltage: AC100-250V, 50-60Hz
Maximum power consumption: 400W
Light source: 4PCS*100W COB
Lamp bead life: more than 50,000 hours
Channel: 6/12CH
Mode: DMX512, self-propelled, master-slave, central control
Operation interface: LED digital tube display
Control mode: self-propelled, voice control, master-slave, DMX512
Strobe: Electronic strobe, 0-30 times/second
Signal: Three-core signal input and output
Power supply: PowerCon in/out
Effect: 0-100% smooth linear dimming, no jitter; refresh frequency 20500Hz.
Using a stable constant current drive and power supply, suitable for video shooting
The illumination transition is balanced, with no speckle, and no visible relative dark area.
LED optical system: high-efficiency optical system, The heat dissipation material of the lamp bead head is high heat dissipation, high-density die-casting aluminum material,
Waterproof grade: IP65

技术参数

额定电压: AC100-250V, 50-60Hz
最大功耗: 400W
光源: 4PCS*100W COB
灯珠寿命: 大于50000小时
通道: 6/12CH
模式: DMX512、自走、主从、中控
操作界面: LED数码管显示
控制方式: 自走、声控、主从、DMX512
频闪: 电子频闪, 0-30次/秒
信号: 三芯信号输入/输出
电源: PowerCon 输入/输出
效果: 0-100%平滑线性调光, 无抖动; 刷新频率20500Hz。
采用稳定的恒流驱动和电源, 适合视频拍摄
照明过渡平衡, 无散斑, 也没有可见的相对暗区。
LED光学系统: 高效光学系统, 灯珠头散热材料采用高散热高密度压铸铝材质, 防水等级: IP65

KL-BL2150P-3

2眼防水观众灯 2 Eyes Waterproof Blinder Light



Technical Specifications

Power Consumption: 350W
Light Source: 2pcs*150W C/W LED
Led Lifespan: 50000hours
Control Mode: DMX512/Auto/Sound Active/Master-slave
DMX Channel: 2/3/5channels
Dimmer: 0-100% linear dimming, separate strobe
Working Temperature: -20°C to 40°C
Display: LCD display
IP Rating: IP65
Dimension: 400*200*235mm
N.W: 8kg

技术参数

功耗: 350W
光源: 2颗*150W C/W LED
LED寿命: 50000小时
控制模式: DMX512/自走/声控/主从
DMX通道: 2/3/5通道
调光器: 0-100%线性调光, 独立频闪
工作温度: -20°C至40°C
显示: 液晶显示
防护等级: IP65
尺寸: 400*200*235mm
净重: 8kg

KL-LM2515**25颗*15W LED 矩阵灯**
25PCS*15W LED Matrix Light**Technical Specifications**

Light source: 25pcs*15W LED
Dimmer: 0-100% linear dimming
Strobe: 0-25 times/second
Main performance: high power and high brightness LED, high efficiency, and energy saving;
Four-digit display, with power supply and signal indication;
Auto power off function; independent operation, DMX control, master control, and Slave synchronous operation; preset programs and self-propelled scenes;
Quick installation and then designed to facilitate a variety of combinations; overtemperature protection.
Rated voltage: AC 110/230V, 50/60Hz
Rated power: 330W
Working mode: DMX mode, master-slave mode
DMX channel: 5/25/30CH
Ambient temperature: -25°C~40°C
Cooling method: powerful air cooling
IP 20

技术参数

光源:25颗*15W LED
调光器:0-100%线性调光
频闪:0-25次/秒
主要性能:大功率高亮度LED, 高效节能;
四位显示, 具有电源和信号指示;
自动断电功能; 独立运行, DMX控制、主控、从机同步运行; 预设程序和自走场景;
快速安装再设计, 方便多种组合; 超温保护。
额定电压: 交流110/230V, 50/60Hz
额定功率: 330W
工作模式: DMX模式、主从模式
DMX通道: 5/25/30CH
环境温度: -25°C~40°C
冷却方式: 强力风冷
防护等级20

KL-LM3603**36颗*3W LED 矩阵灯**
36PCS*3W LED Matrix Light**Technical Specifications**

Voltage: AC90-240V, 50/60Hz
Power: 120W
Light source: 36pcs*3W LED
Two channel modes: 5/36 channels
Control mode: DMX, ArtNet, master, voice control
Signal protocol: DMX protocol
Screen display: Chinese and English
LCD display
Main features: compact, excellent heat dissipation design; lightweight, easy to install; liquid crystal display, easy to operate
LED can be controlled by a dot matrix to Create various lighting effects 0-100% smooth
Adjustable multi-frequency flash speed
Size: 550*550*250mm
Net weight: 7.35 kg
Gross weight: 8.05 kg

技术参数

电压:AC90-240V, 50/60Hz
功率:120W
光源:36颗*3W LED
两种通道模式:5/36通道
控制方式:DMX、ArtNet、主控、声控
信号协议:DMX协议
屏幕显示:中文、英文
液晶显示器
主要特点:结构紧凑, 优良的散热设计; 重量轻, 易于安装; 液晶显示, 操作方便
LED可以通过点阵控制来创造0-100%平滑的各种灯光效果
多频闪光速度可调
尺寸:550*550*250mm
净重:7.35公斤
毛重:8.05公斤

KL-LM2530**25颗*30W LED 矩阵灯**
25PCS*30W LED Matrix Light**Technical Specifications**

Light source: 25PCS*30W LED
Voltage: AC 100 - 240V, 50/60Hz
Maximum power: 800W
Drive mode: constant current
Control mode: DMX, self-propelled, master-slave mode
DMX channel: 8/80 channel
Built-in automation program, 100 built-in programs
Electronic dimming: 0-100% linear dimming
Strobe: 1-20 times/second
Heat dissipation: powerful air cooling
IP class: IP 20
Convenient quick-lock system with multiple links
Dimensions: 580 x 580 x 125mm
Package size: 680*680*180mm
Net weight: 15.5KG

技术参数

光源:25PCS*30W LED
电压:交流100 - 240V, 50/60Hz
最大功率:800W
驱动方式:恒流
控制模式:DMX、自走、主从模式
DMX通道:8/80通道
内置自动化程序, 100个内置程序
电子调光:0-100%线性调光
频闪:1-20次/秒
散热方式:强力风冷
防护等级:IP 20
方便的快速锁定系统, 具有多个链接
尺寸:580×580×125mm
包装尺寸:680*680*180mm
净重:15.5KG

KL-LM0530**5颗*30W LED 矩阵灯**
5PCS*30W LED Matrix Light**Technical Specifications**

Light source: 5PCS*30W LED
Voltage: AC 100 - 240V, 50/60Hz
Maximum power: 200W
Drive mode: constant current
Control mode: DMX, self-propelled, master-slave mode
DMX channel: 8/80 channel
Built-in automation program, 100 built-in programs
Electronic dimming: 0-100% linear dimming
Strobe: 1-20 times/second
Heat dissipation: powerful air cooling
IP class: IP 20
Convenient quick-lock system with multiple links
Dimensions: 580*580*125 mm

技术参数

光源:5PCS*30W LED
电压:交流100 - 240V, 50/60Hz
最大功率:200W
驱动方式:恒流
控制模式:DMX、自走、主从模式
DMX通道:8/80通道
内置自动化程序, 100个内置程序
电子调光:0-100%线性调光
频闪:1-20次/秒
散热方式:强力风冷
防护等级:IP 20
方便的快速锁定系统, 具有多个链接
尺寸:580*580*125毫米

KL-LW1815**18颗*15W LED点控洗墙灯****18PCS*15W LED Point Control Wall Washer Light****Technical Specifications**

Power Consumption: 450W
 Input voltage: AC90-240V, 50/60HZ
 Light source: 18pcs*15W 3in1 LED
 LED life: 50000~100000 hours
 LED PWM dimming frequency: >400Hz
 DMX channel: 2/3/5/8/42/44CH
 Control mode: DMX512/self-propelled/voice-activated/master-slave
 Function effect: dimming/strobe/color mixing/gradient/single control
 Cooling method: natural convection
 Protection class: IP65
 Strobe: 1-18 times/second
 Luminous color: R G B W mixed
 Beam angle: 15-45° (optional)
 Product size: 100*22*10mm
 Weight: 8.15KG

技术参数

功耗:450W
 输入电压:AC90-240V, 50/60HZ
 光源:18颗*15W 3in1 LED
 LED寿命:50000~100000小时
 LED PWM调光频率:>400Hz
 DMX通道:2/3/5/8/42/44CH
 控制模式:DMX512/自走/声控/主从
 功能效果:调光/频闪/混色/渐变/单控
 冷却方式:自然对流
 防护等级:IP 65
 频闪:1-18次/秒
 发光颜色:R G B W混合
 光束角度:15-45°(可选)
 产品尺寸:100*22*10mm
 重量:8.15KG

KL-LW1410P**14颗*10W LED 防水洗墙灯****14PCS*10W LED Waterproof Wall Washer Light****Technical Specifications**

Power Consumption: 450W
 Input voltage: AC90-240V, 50/60HZ
 Light source: 14pcs*10W 3in1 LED
 LED life: 50000~100000 hours
 LED PWM dimming frequency: >400Hz
 DMX channel: 2/3/5/8/42/44CH
 Control mode: DMX512/self-propelled/voice-activated/master-slave
 Function effect: dimming/strobe/color mixing/gradient
 Cooling method: natural convection
 Protection class: IP65
 Strobe: 1-18 times/second
 Luminous color: R G B W mixed
 Beam angle: 15-45° (optional)
 Product size: 100*22*10mm
 Weight: 8.15KG

技术参数

功耗:450W
 输入电压:AC90-240V, 50/60HZ
 光源:14颗*10W 3in1 LED
 LED寿命:50000~100000小时
 LED PWM调光频率:>400Hz
 DMX通道:2/3/5/8/42/44CH
 控制模式:DMX512/自走/声控/主从
 功能效果:调光/频闪/混色/渐变
 冷却方式:自然对流
 防护等级:IP 65
 频闪:1-18次/秒
 发光颜色:R G B W混合
 光束角度:15-45°(可选)
 产品尺寸:100*22*10mm
 重量:8.15KG

KL-LW1810P**18颗*10W LED 防水洗墙灯****18PCS*10W LED Waterproof Wall Washer Light****Technical Specifications**

Power Consumption: 450W
 Input voltage: AC90-240V, 50/60HZ
 Light source: 18pcs*10W 3in1 LED
 LED life: 50000~100000 hours
 LED PWM dimming frequency: >400Hz
 DMX channel: 2/3/5/8/42/44CH
 Control mode: DMX512/self-propelled/voice-activated/master-slave
 Function effect: dimming/strobe/color mixing/gradient
 Cooling method: natural convection
 Protection class: IP65
 Strobe: 1-18 times/second
 Luminous color: R G B W mixed
 Beam angle: 15-45° (optional)
 Product size: 100*22*10mm
 Weight: 8.15KG

技术参数

功耗:450W
 输入电压:AC90-240V, 50/60HZ
 光源:18颗*10W 3in1 LED
 LED寿命:50000~100000小时
 LED PWM调光频率:>400Hz
 DMX通道:2/3/5/8/42/44CH
 控制模式:DMX512/自走/声控/主从
 功能效果:调光/频闪/混色/渐变
 冷却方式:自然对流
 防护等级:IP 65
 频闪:1-18次/秒
 发光颜色:R G B W混合
 光束角度:15-45°(可选)
 产品尺寸:100*22*10mm
 重量:8.15KG

KL-LW2410**24颗*10W LED 洗墙灯****24PCS*10W LED Wall Washer Light****Technical Specifications**

Light source: 24*10W RGBW
 Lens angle: 25°
 (45°/60°optional)
 Power input: AC100-240V, 50-60HZ
 Total power: 250W
 Channel: 8CH
 Control: console, stand-alone self-propelled, voice control
 Lamp housing material: Formed aluminum
 Protection class: IP65
 Lamp size: 100*9*16CM
 Packing size: 108*11*17CM
 Net weight: 7Kg
 Gross weight: 8Kg

技术参数

光源:24*10W RGBW
 镜头角度:25°(45°/60°可选)
 电源输入:AC100-240V, 50-60HZ
 总功率:250W
 频道:8CH
 控制方式:控制台、独立自走、声控
 灯壳材质:成型铝
 防护等级:IP65
 灯具尺寸:100*9*16CM
 包装尺寸:108*11*17CM
 净重:7Kg
 毛重:8Kg

KL-YL0306

6眼摇头激光灯

6 Eyes Moving Head Laser Light

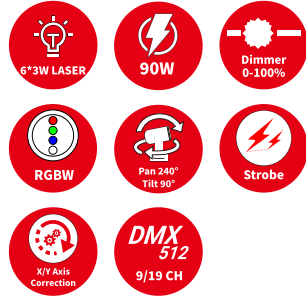

KL-YL0708

7颗LED+8眼激光灯

7PCS LED+8 Eyes Laser Light

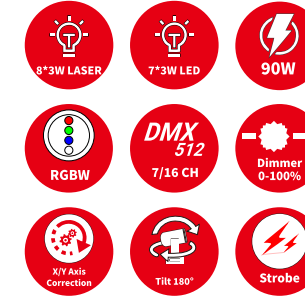

Technical Specifications

Light Source
Total Laser Power: 3W red laser
Laser Power/Wavelength: 6pcs 500mW 638nm red
Laser Safety: Class 3B

Optical System
Features: semi-conduct laser diode with long lifespan and stable performance
laser beam size: 3.5cm at 3m distance, single laser control

Control Program
Control Mode: DMX/Auto/Sound/Master-slave
DMX Channel: 9/19-1/19-2CH
Display: LED display with 4 buttons

Function Effect
1. 6pcs fat beam laser diodes
2. Single laser diode control
3. semi-conduct laser diode with stable performance and long lifespan
4. Sweeping fat beam with Tilt of 90° and Pan 240° to make a great and cost-effective beam show,
5. applicable for disco, club, KTV, pub, Bar, etc.

Pan/Tilt Axis
Pan: 240°
Tilt: 90°

Electrical Control
Power Consumption: 90W
Input Voltage: AC 100-240V 50/60Hz
3pin DMX input/output, Power Con input/output,

Lighting Specification
Height: 129mm
Width: 230mm
Length: 1000mm
IP Rating: IP20
N.W.(KG): 12.9KG
G.W.(KG): 15.1KG
Carton Size: 124*46*33cm (2pcs/carton, G.W: 34.2KG)

技术参数

光源
总激光功率: 3W 红光激光
激光功率/波长: 6颗 500mW 638nm 红色
激光安全: 3B 级

光学系统
特点: 半导体激光二极管, 寿命长, 性能稳定
激光束尺寸: 3m 距离处 3.5cm, 单激光控制

控制程序
控制模式: DMX/自走/声控/主从
DMX通道: 9/19-1/19-2CH
显示: LED显示, 带4个按钮

功能效果
1. 6颗宽束激光二极管
2. 单激光二极管控制
3. 半导体激光二极管, 性能稳定, 寿命长
4. 横扫粗壮光束, 倾斜90°、水平240°, 打造精彩且高性价比的光束秀,
5. 适用于迪斯科、俱乐部、KTV、酒馆、酒吧等。

平移/倾斜轴
平移: 240°
倾斜: 90°

电气控制
功耗: 90W
输入电压: AC 100-240V 50/60Hz
3pin DMX输入/输出, Power Con输入/输出,

照明规格
高度: 129毫米
宽度: 230毫米
长度: 1000毫米
防护等级: IP20
净重(KG): 12.9KG
毛重(KG): 15.1KG
纸箱尺寸: 124*46*33cm (2个/箱, 毛重: 34.2KG)

Technical Specifications

Light Source
Total Laser Power: 4W RGB laser
Laser Power/Wavelength: 8pcs 500mW 638nm red
Laser Safety: Class 3B
LED: 7*3W Amber LED (beam angle 7°)

Optical System
Effect: 0-100% smooth linear dimming, no jitter; refresh frequency 20500Hz.
Illumination transition is balanced, with no speckle, no visible relative dark area
Remarks: Other RG, GB, RB, and RGB color versions are available too!

Control Program
Modulation: TTL
Control Mode: DMX/Auto/Sound/Master-slave
DMX Channel: 7/16CH
Display: LED display with 4 buttons
Scan System: stepping motor

Function Effect
1. 8pcs fat beam laser diodes
2. Single laser diode control
3. 7pcs 3W amber LED with beam angle 7°
4. projects strong and sweeping fat beam with 180° TILT, and makes a great and cost-effective beam show,
5. Applicable for disco, club, KTV, pub, Bar, family party etc.

Tilt Axis
Tilt: 180°

Electrical Control
Power Consumption: 68W
Input Voltage: AC 100-240V 50/60Hz

Lighting Specification
Height: 173mm
Width: 84mm
Length: 1000mm
IP Rating: IP20
Weight: 12KG
N.W.(KG): 6.8KG
G.W.(KG): 7.3KG
Carton Size: 122*36*25cm (2pcs/carton)

技术参数

光源
总激光功率: 4W RGB 激光
激光功率/波长: 8颗 500mW 638nm 红色
激光安全: 3B 级
LED: 7*3W 琥珀色LED (光束角7°)

光学系统
效果: 0-100%平滑线性调光, 无抖动; 刷新频率20500Hz。
光照过渡均衡, 无散斑, 无可见相对暗区
备注: 还有其他RG、GB、RB、RGB颜色版本可供选择!

控制程序
调制方式: TTL
控制模式: DMX/自走/声控/主从
DMX通道: 7/16CH
显示: LED显示, 带4个按钮
扫描系统: 步进电机

功能效果
1. 8颗宽束激光二极管
2. 单激光二极管控制
3. 7颗3W琥珀色LED, 光束角7°
4. 180°倾斜, 投射强劲、扫掠的脂肪光束, 打造精彩且高性价比的光束秀,
5. 适用于迪斯科、俱乐部、KTV、酒馆、酒吧、家庭聚会等。

倾斜轴
倾斜: 180°

电气控制
功耗: 68W
输入电压: AC 100-240V 50/60Hz

照明规格
高度: 173毫米
宽度: 84毫米
长度: 1000毫米
防护等级: IP20
重量: 12KG
净重(KG): 6.8KG
毛重(公斤): 7.3公斤
纸箱尺寸: 122*36*25cm (2个/箱)

KL-YL10/08 10W/8W 全彩激光灯 10W/8W Full Color Laser Light



Technical Specifications

Power Consumption: 90W
Input Voltage: AC 100-240V 50/60Hz
Total Laser Power: 10W RGB semiconductor integrated laser
Laser Power/Wavelength: Red-1500mW/638nm, Green-2000mW/520nm, Blue-4500mW/445nm
Scan System: ILDA 30K scanner
Scanning Angle: ±30°
Modulation: Analog Modulation
Control Mode: DMX-512/Auto/Sound Active/Master-Slave/PC
DMX Channel: 17CH
Internal Pattern: 256 patterns
SD Card: with 1PC SD card
Display: LCD display with knob
IP Rating: IP20
Dimension 30*26*17cm
N.W: 7.5KG
Features:
1. RGB full-color laser light with a high-speed scanner to create a beam show, a logo show, and a text show.
2. Support laser show software, e.g. Panglin, Phoenix, and Mamba.
3. Use the SD card to save patterns and then press the buttons on the LCD display or use the DMX controller to select patterns saved in the SD card.
4. Max 16 units work synchronously under the control of the computer.
5. Safety capacity: design according to security and good performance, safe to humans and the environment.
6. Auto close light when the scanner has trouble.
7. Applicable for disco, club, KTV, pub, Bar, family party, etc.

技术参数

功耗: 90W
输入电压: AC 100-240V 50/60Hz
激光总功率: 10W RGB半导体集成激光器
激光功率/波长: 红色-1500mW/638nm, 绿色-2000mW/520nm, 蓝色-4500mW/445nm
扫描系统: ILDA 30K扫描仪
扫描角度: ±30°
调制方式: 模拟调制
控制模式: DMX-512/自走/声控/主从/PC
DMX通道: 17CH
内部图案: 256个图案
SD卡: 带1PC SD卡
显示: 液晶显示, 带旋钮
防护等级: IP20
尺寸: 30*26*17cm
净重: 7.5KG
特征:
1. RGB全彩激光灯搭配高速扫描仪, 可产生光束秀、标志秀、文字秀。
2. 支持Panglin, Phoenix, Mamba等激光表演软件。
3. 使用SD卡保存花样, 然后按LCD显示屏上的按钮或使用DMX控制器选择SD卡中保存的花样。
4. 电脑控制下最多16台同步工作。
5. 安全能力: 按安全性设计, 性能良好, 对人体和环境安全。
6. 扫描仪出现故障时自动关闭灯。
7. 适用于迪斯科、俱乐部、KTV、酒馆、酒吧、家庭聚会等。



KL-YL03 3W 全彩激光灯 3W Full Color Laser Light

Technical Specifications

Power Consumption: 70W
Input Voltage: AC 100-240V 50/60Hz
Total Laser power RGB Synthetic laser
Laser Power/Wavelength: Red: 600mW/638nm Green: 600mW/520nm Blue: 1800mW/445nm
Scan System: ILDA 30K scanner
Laser Safety: Class 4B
Modulation: TTL
Control Mode: DMX/Auto/Sound/Master-slave/ILDA
DMX Channel: 17CH
Scanning Angle: ±30°
Internal Pattern: 256 patterns
SD Card: SD card for option
Display: LCD display with knob
Other Function: With power output adjustment of each color
IP Rating: IP20
N.W.(KG): 4.1KG
G.W.(KG): 5.0KG
Product Dimension: 264*250*232.5mm
Carton Size: 30*25*26cm
1. RGB full-color laser light with a high-speed scanner to create a beam show, a logo show, and a text show.
2. Support laser show software, e.g. Panglin, Phoenix, Mamba
3. Auto switch between the internal program and PC
4. Max 16 units work synchronously under the control of a computer
5. Safety capacity: design according to security and good performance, safe to humans and the environment.
6. Auto close light when the scanner has trouble
7. Applicable for disco, club, KTV, pub, Bar, family party, etc.

技术参数

功耗: 70W
输入电压: AC 100-240V 50/60Hz
总激光功率 RGB 合成激光
激光功率/波长: 红色: 600mW/638nm 绿色: 600mW/520nm 蓝色: 1800mW/445nm
扫描系统: ILDA 30K扫描仪
激光安全: 4B级
调制方式: TTL
控制模式: DMX/自走/声控/主从/ILDA
DMX通道: 17CH
扫描角度: ±30°
内部图案: 256个图案
SD卡: SD卡可选
显示: 液晶显示, 带旋钮
其他功能: 具有各颜色功率输出调节
防护等级: IP20
净重(KG): 4.1KG
毛重(KG): 5.0KG
产品尺寸: 264*250*232.5mm
纸箱尺寸: 30*25*26cm
1. RGB全彩激光灯配合高速扫描仪打造光束秀、标志秀、文字秀
2. 支持激光表演软件, 例如Panglin, Phoenix, Mamba
3. 内部程序与PC自动切换
4. 电脑控制下最多16台同步工作
5. 安全能力: 按安全性设计, 性能良好, 对人体和环境安全。
6. 扫描仪出现故障时自动关闭灯
7. 适用于迪斯科、俱乐部、KTV、酒馆、酒吧、家庭聚会等。



KL-YL05 5W 全彩激光灯 5W Full Color Laser Light

Technical Specifications

Power Consumption: 78W
Input Voltage: AC 100-240V 50/60Hz
Total Laser Power: 5W RGB semiconductor integrated laser
Laser Power/Wavelength: Red: 1000mW/638nm Green: 1500mW/520nm Blue: 2500mW/445nm
Scan System: ILDA 30K scanner
Scanning Angle: ±30°
Modulation: Analog Modulation
Control Mode: DMX-512/Auto/Sound Active/Master-Slave/PC
DMX Channel: 17CH
Internal Pattern: 256 patterns
SD Card: with 1PC SD card
Display: LCD display with knob
IP Rating: IP20
Dimension 30*26*17cm
N.W: 7.5KG
Features:
1. RGB full-color laser light with a high-speed scanner to create a beam show, a logo show, and a text show.
2. Support laser show software, e.g. Panglin, Phoenix, and Mamba.
3. Use the SD card to save patterns and then press the buttons on the LCD display or use the DMX controller to select patterns saved in the SD card.
4. Max 16 units work synchronously under the control of a computer.
5. Safety capacity: design according to security and good performance, safe to humans and the environment.
6. Auto close light when the scanner has trouble
7. Applicable for disco, club, KTV, pub, Bar, family party, etc.

技术参数

功耗: 78W
输入电压: AC 100-240V 50/60Hz
激光总功率: 5W RGB半导体集成激光器
激光功率/波长: 红光: 1000mW/638nm 绿色: 1500mW/520nm 蓝色: 2500mW/445nm
扫描系统: ILDA 30K扫描仪
扫描角度: ±30°
调制方式: 模拟调制
控制模式: DMX-512/自走/声控/主从/PC
DMX通道: 17CH
内部图案: 256个图案
SD卡: 带1PC SD卡
显示: 液晶显示, 带旋钮
防护等级: IP20
尺寸: 30*26*17cm
净重: 7.5KG
特征:
1. RGB全彩激光灯搭配高速扫描仪, 可产生光束秀、标志秀、文字秀。
2. 支持Panglin, Phoenix, Mamba等激光表演软件。
3. 使用SD卡保存花样, 然后按LCD显示屏上的按钮或使用DMX控制器选择SD卡中保存的花样。
4. 电脑控制下最多16台同步工作
5. 安全能力: 按安全性设计, 性能良好, 对人体和环境安全。
6. 扫描仪出现故障时自动关闭灯
7. 适用于迪斯科、俱乐部、KTV、酒馆、酒吧、家庭聚会等。

KL-YL4P04 4头RGBY激光灯 4PCS RGBY laser lights

Technical Specifications

Power supply: AC 110/220V 50/60Hz
Power: Red 200mw(650nm), Green 80mw (532nm), Blue 200mw (450nm)
Control system: DMX512, voice control, automatic, master-slave synchronization
Features: 6-channel control, with "black field" function; four heads and four lines effect.
Dimensions: 625mm*160mm*150mm double handle 45mm+50mm
Weight: 6KG

技术参数

电源: 交流110/220V 50/60Hz
功率: 红200mw (650nm), 绿80mw (532nm), 蓝200mw (450nm)
控制系统: DMX512、声控、自动、主从同步
特点: 6通道控制, 具有“黑场”功能; 四头四线效果。
尺寸: 625mm*160mm*150mm
双手柄: 45mm+50mm
重量: 6KG



KL-LDF1212

12*12数码地砖灯

12*12 Digital LED Dance Floor Light

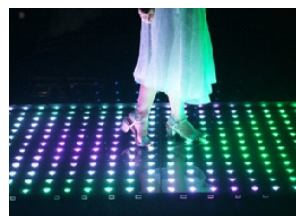
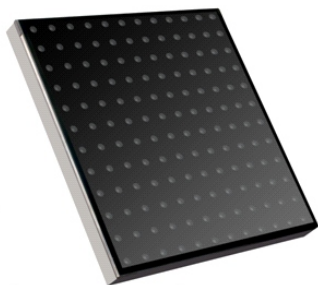

Technical Specifications

Rated voltage: AC100-240V, 50/60Hz
 Maximum power: 15W
 Light source: LED5050 SMD 3in 1
 Service life: $\geq 50,000$ hours
 Control method: SD control (with remote control, DMX, audio, voice control), online control, applicable to MADRIX software
 Working temperature: $-20 \sim +60^{\circ}\text{C}$
 Product size: $500 \times 500 \times 70\text{mm}$
 Net quantity: 10KG
 Rated voltage: AC100-240V, 50/60Hz

技术参数

额定电压: AC100-240V, 50/60Hz
 最大功率: 15W
 光源: LED5050 SMD 3in 1
 使用寿命: $\geq 50,000$ 小时
 控制方式: SD控(可带遥控, DMX, 音频, 声控), 联机控, 可适用于MADRIX软件
 工作温度: $-20 \sim +60^{\circ}\text{C}$
 产品尺寸: $500 \times 500 \times 70\text{mm}$
 净量: 10KG
 额定电压: AC100-240V, 50/60Hz

KL-LDF5050-1

深渊地砖灯

Abyss LED Dance Floor Light

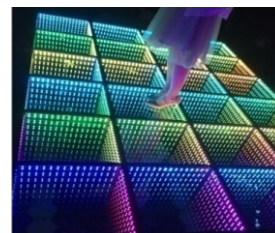
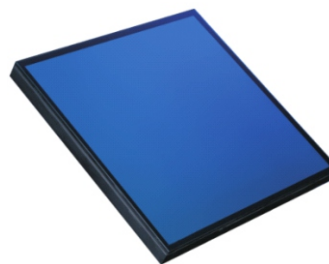

Technical Specifications

Rated voltage: AC100-240V, 50/60Hz
 Maximum power: 10W
 Light source: LED5050 SMD 3in 1
 Service life: $\geq 50,000$ hours
 Control method: SD control (with remote control, DMX, audio, voice control), online control, applicable to MADRIX software
 Working temperature: $-20 \sim +60^{\circ}\text{C}$
 Product size: $500 \times 500 \times 70\text{mm}$
 Net quantity: 10KG
 Rated voltage: AC100-240V, 50/60Hz

技术参数

额定电压: AC100-240V, 50/60Hz
 最大功率: 10W
 光源: LED5050 SMD 3in 1
 使用寿命: $\geq 50,000$ 小时
 控制方式: SD控(可带遥控, DMX, 音频, 声控), 联机控, 可适用于MADRIX软件
 工作温度: $-20 \sim +60^{\circ}\text{C}$
 产品尺寸: $500 \times 500 \times 70\text{mm}$
 净量: 10KG
 额定电压: AC100-240V, 50/60Hz

KL-LDF5050-2

双层地砖灯

Double LED Dance Floor

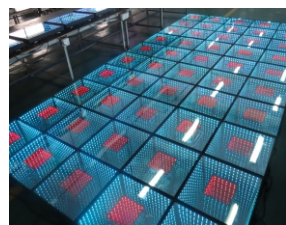
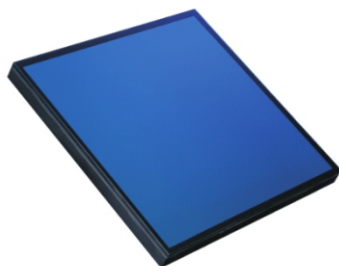

Technical Specifications

Rated voltage: AC100-240V, 50/60Hz
 Maximum power: 12W
 Light source: LED5050 SMD 3in 1
 Service life: $\geq 50,000$ hours
 Control method: SD control (with remote control, DMX, audio, voice control), online control, applicable to MADRIX software
 Working temperature: $-20 \sim +60^{\circ}\text{C}$
 Product size: $500 \times 500 \times 70\text{mm}$
 Net quantity: 10KG
 Rated voltage: AC100-240V, 50/60Hz

技术参数

额定电压: AC100-240V, 50/60Hz
 最大功率: 12W
 光源: LED5050 SMD 3in 1
 使用寿命: $\geq 50,000$ 小时
 控制方式: SD控(可带遥控, DMX, 音频, 声控), 联机控, 可适用于MADRIX软件
 工作温度: $-20 \sim +60^{\circ}\text{C}$
 产品尺寸: $500 \times 500 \times 70\text{mm}$
 净量: 10KG
 额定电压: AC100-240V, 50/60Hz

KL-LDF0808

8*8数码地砖灯

12*12 Digital LED Dance Floor

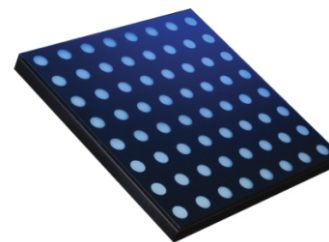

Technical Specifications

Rated voltage: AC100-240V, 50/60Hz
 Maximum power: 15W
 Light source: LED5050 SMD 3in 1
 Service life: $\geq 50,000$ hours
 Control method: SD control (with remote control, DMX, audio, voice control), online control, applicable to MADRIX software
 Working temperature: $-20 \sim +60^{\circ}\text{C}$
 Product size: $500 \times 500 \times 70\text{mm}$
 Net quantity: 10KG
 Rated voltage: AC100-240V, 50/60Hz

技术参数

额定电压: AC100-240V, 50/60Hz
 最大功率: 15W
 光源: LED5050 SMD 3in 1
 使用寿命: $\geq 50,000$ 小时
 控制方式: SD控(可带遥控, DMX, 音频, 声控), 联机控, 可适用于MADRIX软件
 工作温度: $-20 \sim +60^{\circ}\text{C}$
 产品尺寸: $500 \times 500 \times 70\text{mm}$
 净量: 10KG
 额定电压: AC100-240V, 50/60Hz

KL-F1500U 1500W 气柱烟机 150W Up Fog Machine



Technical Specifications

Power supply: AC100-240V, 50-60Hz
 Power consumption: 1500W
 LED Source: 24*3W 3in1 RGB High brightness LEDs
 Smoke output: 4200cuft/min
 Control mode: DMX control, wireless control, and LED display control
 DMX Channel: 8CHS
 Oil Consumption Rate: 8min/1L
 Tank capacity: 2.5L

技术参数

电源: AC100-240V, 50-60Hz
 功耗: 1500W
 LED光源: 24颗3W 3合1 RGB高亮度LED
 排烟量: 4200立方英尺/分钟
 控制方式: DMX控制、无线控制、LED显示控制
 DMX通道: 8CHS
 油耗率: 8分钟/1L
 水箱容量: 2.5L

KL-F900/1500 900W/1500W 烟机 900W/1500W Fog Machine



Technical Specifications

Voltage: AC 110/230V 50-60Hz ± 10%
 Power: 900W
 Warm-up time: 6
 Smoke oil capacity: 2L
 Smoke distance: 10M
 Smoke covered: 18000cu.ft/min
 Control mode: remote control
 N.W: 4kg
 G.W: 4.6kg
 Product size: 33.5*19.5*15.5cm
 Package Size: 42*26*23cm
 6in1box: 42*26*23cm

技术参数

电压: 交流110/230V 50-60Hz ± 10%
 功率: 900W
 预热时间: 6
 烟油容量: 2L
 烟雾距离: 10M
 烟雾覆盖: 18000cu.ft/min
 控制方式: 遥控
 净重: 4kg
 毛重: 4.6kg
 产品尺寸: 33.5*19.5*15.5cm
 包装尺寸: 42*26*23cm
 6合1盒: 42*26*23cm

KL-F3000 3000W 烟机 3000W Fog Machine



Technical Specifications

Voltage: AC 110/230V 50-60Hz ± 10%
 Power: 3000W
 Warm-up Time: 12 minutes
 Oil smoke capacity: 6 liters;
 Smoke distance: 20 meters
 Smoke covered: 40000cu.ft/min
 Control mode: time quantitative / DMX512 Control
 Product Size: 72 × 30.5 × 24.5cm
 Package size: 77 × 40 × 30cm
 N.W: 10.5kg
 G.W: 12kg

技术参数

电压: 交流110/230V 50-60Hz ± 10%
 功率: 3000W
 预热时间: 12分钟
 烟油容量: 6升;
 烟雾距离: 20米
 烟雾覆盖量: 40000cu.ft/min
 控制方式: 时间定量/DMX512控制
 产品尺寸: 72 × 30.5 × 24.5cm
 包装尺寸: 77 × 40 × 30cm
 净重: 10.5kg
 毛重: 12kg

KL-F1000 1000W薄雾机 1000W Fog Machine



Technical Specifications

Voltage: AC 110/230V 50-60Hz ± 10%
 Power: 1500W
 Warm-up Time: 10 minutes
 Oil smoke capacity: 5 liters
 Spray distance: 15 meters
 Smoke covered: 25000cu.ft/min
 Control mode: remote control
 Product Size: 51*26*21.5cm
 Package size: 52*32.5*26cm
 N.W: 6.8kg
 G.W: 7.8kg R/G/B (single color)

技术参数

电压: 交流110/230V 50-60Hz ± 10%
 功率: 1500W
 预热时间: 10分钟
 烟油容量: 5升
 喷射距离: 15米
 烟雾覆盖量: 25000cu.ft/min
 控制方式: 遥控
 产品尺寸: 51*26*21.5cm
 包装尺寸: 52*32.5*26cm
 净重: 6.8kg
 毛重: 7.8kg R/G/B (单色)

KL-H600 600W 双雾机 600W Haze Machine

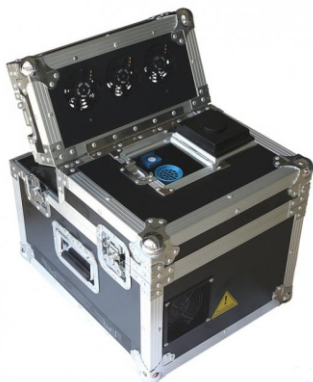

Technical Specifications

Voltage: AC 220V-240V / 50-60Hz
Power: 660W
Preheating time: No need to preheat, continuous smoke
Oil barrel capacity: 3L
Fuel consumption: 1 liter can be used continuously for 25 hours
Fan angle: adjustable
DMX512 signal: support 512 signal control
Display: LCD liquid crystal control panel, remote control
Shell: With flight case
Product size: 500*380*430mm
Packing size: 500*380*430mm
Gross weight: 31Kg

技术参数

电压: 交流220V-240V/50-60Hz
功率: 660W
预热时间: 无需预热, 持续冒烟
油桶容量: 3L
油耗: 1升可连续使用25小时
风扇角度: 可调
DMX512信号: 支持512信号控制
显示: LCD液晶控制面板、遥控器
外壳: 带航空箱
产品尺寸: 500*380*430mm
包装尺寸: 500*380*430mm
毛重: 31Kg

KL-FW3000 3000W水雾机 3000W Water Fog Machine



Technical Specifications

Power: 3000W
Voltage: 110V 60HZ / 220V 50HZ
Control: digit display, remote control, DMX512 control
Consumables: Water low fog liquid, common water, temperature 25-40°C
Coverage: about 100m²
DMX channel: 2CH
N.W.: 16.8KG
G.W.: 34KG
Size: 62.5*35*42Cm
Packing Size: 69 * 43 * 55CM

技术参数

功率: 3000W
电压: 110V 60HZ / 220V 50HZ
控制方式: 数显、遥控、DMX512控制
耗材: 水低雾液、普通水, 温度25-40°C
面积: 约100m²
DMX通道: 2CH
净重: 16.8KG
毛重: 34KG
尺寸: 62.5*35*42Cm
包装尺寸: 69*43*55CM

KL-ECS400 400W 冷烟花机 400W Cold Spark Machine



Technical Specifications

Voltage: AV120V-220V 50/60Hz
Rated Power: 570w
Fuse: 4A or 8A
Spark Initial Warm-up Time: <8mins
Spark Height: 1-5M
Spark Height Adjust:
Support DMX-512
Support DMX Channel: 2CH
Wireless Remote W-9
Display Board: Digital display board
Gross Weight: 7.8KG
Packaging Volume(mm): 300*300*320mm

技术参数

电压: AV120V-220V 50/60Hz
额定功率: 570w
保险丝: 4A或8A
Spark初始预热时间: <8分钟
火花高度: 1-5M
火花高度调节: 支持DMX-512
支持DMX通道: 2CH
无线遥控器 W-9
显示板: 数字显示板
毛重: 7.8KG
包装体积(mm): 300*300*320mm

KL-B300 300W 泡泡机 300W Double Bubble Machine



Technical Specifications

Technical Parameters
Voltage: AC 110/230V 50-60Hz ± 10%
Power: 300W
Bubble oil capacity: 2.5L
Bubble insurance coverage: 200m²
Control mode: remote control 30 meters, manual
N.W: 11kg
G.W: 12.7kg
Product size: 50*38.5*43cm
Package size: 57*48.5*53.5cm

技术参数

技术参数
电压: 交流110/230V 50-60Hz ± 10%
功率: 300W
泡泡油容量: 2.5L
泡沫保险覆盖范围: 200m²
控制方式: 遥控-30米、手动
净重: 11kg
毛重: 12.7kg
产品尺寸: 50*38.5*43cm
包装尺寸: 57*48.5*53.5cm



KL-MC300 五彩喷纸机 Confetti Machine

Technical Specifications

Voltage: AC 110V-230V 50-60Hz±10%
Covered: 300SQM
Control mode: electronic control
Product size: 86*47*59cm
Package Size: 107*107*43cm
N.W: 18.40kg
G.W: 53kg With fly case

技术参数

电压: 交流110V-230V 50-60Hz±10%
覆盖面积: 300平方米
控制方式: 电控
产品尺寸: 86*47*59cm
包装尺寸: 107*107*43cm
净重: 18.40kg
毛重: 53kg 带航空箱

KL-MCL600 LED 五彩喷纸机 LED Confetti Machine



Technical Specifications

Voltage: AC 110 -230V
Power: 1500 W
Control mode: DMX 512 / remote control
DMX channel: 6 channels (DMX mode)
Dimensions: 57 * 33 * 33 cm
Weight: 8 kg
Paper scrap loading: 0.3-0.5kgs
Spray height: 4-6m

技术参数

电压: AC 110 - 230V
功率: 1500瓦
控制方式: DMX 512/遥控
DMX通道: 6通道 (DMX模式)
尺寸: 57*33*33厘米 重量: 8公斤
废纸装载量: 0.3-0.5kgs
喷雾高度: 4-6m

KL-MDI3500 3500W 干冰机 3500W Dry Ice Machine



Technical Specifications

Voltage: AC 110V-240V 50/60HZ
Power: 3500W
Preheating time: 15min
Electronic temperature control
Control: 70°C~80°C
Water consumption: 10L (up to the water line)
maximum continuous output duration: 5~6min
Maximum output cover: 100m²
N.W: 11kg
G.W: 49*49*47cm

技术参数

电压: 交流110V-240V 50/60HZ
功率: 3500W
预热时间: 15分钟
电子温控
控制: 70°C~80°C
用水量: 10L (至水位线)
最大连续输出持续时间: 5~6分钟
最大输出面积: 100m²
净重: 11kg
毛重: 49*49*47cm

KL-MEF06 150W 喷火机 150W Flame Machine



Technical Specifications

Control mode: DMX-512, electric control
Spray flame height: 3M (10ft)
Voltage: 110 v, 220 v ~ 250 v 50/60 hz
Power: 200 w
Packing size: 60*30*25CM
Net weight: 4.2kg
Gross weight: 5.1 kg

技术参数

控制方式: DMX-512、电控
喷雾火焰高度: 3M (10ft)
电压: 110V、220V~250V 50/60Hz
功率: 200瓦
包装尺寸: 60*30*25CM
净重: 4.2kg
毛重: 5.1公斤



KL-MA-Q2B MA2 控台 MA2 Console



KL-DC-TP 双屏老虎触摸控台 Tiger Touch Console Plus

Technical Specifications

Real-time control for up to 65,536 parameters per session in connection with MA NPU (equivalent to 256 DMX universes)
4096 HTP/LTP parameters
6 DMX outputs
2 internal TFT wide mode touchscreens (15.4" WXGA)
1 internal command screen (9" SVGA)*
1 external TFT screen can be connected (UXGA, touchscreens accepted)
15 manual executor faders
Integrated keyboard drawer
2 etherCON connectors
3 USB 2.0 connectors
Motorized monitor wing
Industrial motherboard, built-in SSD, I5CPU, 8Gmemory
Individually backlit and dimmable silent (clickless) keys
AC supply: 110-240V, 50/60Hz
Controller size: 94CM*66CM*21CM
Package size: 100CM*87CM*34CM
NW: 42KG
GW: 75KG

技术参数

与 MA NPU 连接, 实时控制每个会话多达 65,536 个参数 (相当于 256 个 DMX Universe)
4096 HTP/LTP 参数
6 个 DMX 输出
2 个内置 TFT 宽模式触摸屏 (15.4" WXGA)
1 个内部命令屏幕 (9" SVGA)*
可连接 1 个外部 TFT 屏幕 (UXGA, 接受触摸屏)
15 个手动执行器推子
集成键盘抽屉
2 个 etherCON 连接器
3 个 USB 2.0 连接器
机动监控翼
工业主板, 内置SSD, I5CPU, 8G内存
单独背光和可调光静音 (无点击) 按键
交流电源: 110-240V, 50/60Hz
控制器尺寸: 94CM*66CM*21CM
包装尺寸: 100CM*87CM*34CM
净重: 42KG
毛重: 75KG

Technical Specifications

Powerful Titan (Titan) 10.0 operating system
Core i5 CPU, Kingston 120GB high-speed solid state drive, Kingston 4GB memory;
A built-in 15.6-inch high-resolution touchscreen (industrial screen), supports networking to computer equipment to control various lighting 3D visualization software;
Built-in UPS power supply, without access to 220V AC power supply, can operate normally for 1 hour
Support Chinese menu display, built-in multi-language console with 6144 or 3072 channel output, support graffiti-style screen identification function
Support Art-Net network function, expandable to 8 DMX or 4 output lines (domains) and 10 macro function buttons, allowing you to operate the console faster;
20 playback faders, supporting playback of more than 1000 programs;
Powerful attribute control window, CMY\RGB color picker system;
Fast and easy-to-use graphics generator and the classified Built-in graphics are easier to use;
Support the CIPT protocol, you can directly see the image thumbnails of the media clips in the media server on the console;
Support Wi-Fi access, wireless control lamps, mobile devices (iPhone, iPad Touch) remote control lamps;
With thousands of built-in light libraries, and built-in light library editing software, you can edit the light library on the console at any time; Built-in Visualiser line lighting visualization software.
Support MIDI time code sound and light synchronization function, you can also play music on the console to send time code to control the playback of lighting programs.

技术参数

强大的泰坦 (Titan) 10.0 操作系统
酷睿 i5 CPU, 金士顿 120GB 高速固态硬盘、金士顿 4GB 内存;
内置 15.6 英寸高分辨率触摸屏 (工业屏), 支持联网至电脑设备控制各种灯光 3D 可视化软件;
内置 UPS 电源, 无需接入 220V 交流电源, 可正常运行 1 小时
支持中文菜单显示, 内置多语言控制台具有 6144 或 3072 通道输出, 支持涂鸦式屏幕识别功能
支持 Art-Net 网络功能, 可扩展至 8 条 DMX 或 4 条输出线 (域) 和 10 个宏功能按钮, 让您更快地操作控台;
20 个回放推杆, 支持 1000 多个节目回放;
强大的属性控制窗口、CMY\RGB 取色器系统;
快速易用的图形生成器和分类的内置图形更易于使用;
支持 CIPT 协议, 可以在控制台直接看到媒体服务器中媒体片段的图像缩略图;
支持 Wi-Fi 接入, 无线控制灯具, 移动设备 (iPhone、iPad Touch) 远程控制灯具;
内置数千个灯库, 内置灯库编辑软件, 可以随时在控制台上编辑灯库; 内置 Visualiser 线条照明可视化软件。
支持 MIDI 时间码声光同步功能, 还可以在控台播放音乐时发送时间码来控制灯光节目的播放。



KL-DC-T 老虎触摸控制台 Tiger Touch Console

Technical Specifications

Adopt the powerful Titan (Titan) 9.1 version operating system
Core i5 CPU, Kingston 120GB high-speed solid state drive, Kingston 4GB memory;
The console itself is equipped with 12 photoelectric isolation signal output ports (6144 channels) Built-in two 15.6-inch high-resolution touch screens (industrial screens), the screen can be electrically adjusted to an angle between 0 and 125 degrees with a combination of keys on the console.
It is also equipped with a trackball mouse, which is easy to use to select menu operations.
Built-in UPS that can be started without 220V external power supply Taiwan Mingwei switching power supply stable power supply system, Support Chinese menu display, built-in multi-language, support graffiti screen identification function
Support networking to computer equipment to control various lighting 3D visualization software;
10 macro function buttons, allowing you to operate the console faster;
20 playback faders, supporting playback of more than 1000 programs;
Powerful attribute control window, CMY\RGB color picker system;
Support Art-Net network function Fast and easy-to-use graphics generator, and the classified builtin graphics are easier to use;
Support the CIPT protocol, you can directly see the image thumbnails of the media clips in the media server on the console;
Support Wi-Fi access, wireless control lamps, mobile devices (iPhone, iPad Touch) remote control lamps;
With thousands of built-in light libraries, and built-in light library editing software, you can edit the light library on the console at any time;
Built-in Visualiser line lighting visualization software
Support MIDI time code sound and light synchronization function,
You can also play music in the console to send time codes to control the playback of lighting programs.

技术参数

采用强大的泰坦(Titan)9.1版本操作系统
酷睿i5 CPU、金士顿120GB高速固态硬盘、金士顿4GB内存;
控制台本身配备12个光电隔离信号输出口(6144通道)内置两个15.6英寸高分辨率触摸屏(工业屏),屏幕可电动调节0~125度角度组合 控制台上的按键。它还配备了轨迹球鼠标,方便使用选择菜单操作。
内置UPS,无需220V外接电源即可启动
供应台湾明纬开关电源 稳定电源系统,支持中文菜单显示,内置多国语言,支持涂鸦屏识别功能
支持联网到电脑设备控制各种灯光3D可视化软件;
10个宏功能按钮,让您更快地操作控制台;
20个回放推杆,支持1000多个节目回放;
强大的属性控制窗口、CMY\RGB取色器系统;
支持Art-Net网络功能快速易用的图形生成器,分类内置图形更易用;
支持CIPT协议,可以在控制台直接看到媒体服务器中媒体片段的图像缩略图;
支持Wi-Fi接入,无线控制灯具,移动设备(iPhone、iPad Touch)远程控制灯具;
内置数千个灯库,内置灯库编辑软件,可以随时在控制台上编辑灯库;
内置Visualiser线条照明可视化软件
支持MIDI时间码声光同步功能,
还可以在控制台播放音乐时发送时间码来控制灯光节目的播放。



KL-Quartz 石英老虎触摸控制台 Quartz Touch Console

Technical Specifications

The default output is 4 512, the network can output 12 512
• Intel Core I5 processor, 120G solid state hard disk, 4GB running memory, 90 minutes ups power. Built-in 4 DMX output ports, 2048 channels;
Support Art-net network output, which can be expanded to 12 Universe DMX outputs through the network;
Support Titan-net protocol, expandable to 64 Universe DMX outputs
10 mechanical page-turning playback faders;
20 custom macro function keys
Built-in 14.1-inch highlight touch screen, which a Titan Fader wing can extend
20 playback faders, 30 custom macro functions, USB powered)
• Support headphone output
1 Gigabit network interface, support Art-net, Titan-net, Streaming CAN protocols
Compatible with other TITAN system console performance files
• Carton size: 59 * 54 * 29 Carton weight: 13.3KG
• Air box size: 59 * 54 * 35.5 Airbox weight: 22.8Kg"

技术参数

默认输出4个512,网络可输出12个512
• Intel Core I5处理器,120G固态硬盘,4GB运行内存,90分钟UPS电源。内置4个DMX输出口,2048个通道;
支持Art-net网络输出,可通过网络扩展至12个Universe DMX输出;
支持Titan-net协议,可扩展至64个Universe DMX输出
10个机械翻页播放推杆;
20个自定义宏功能键
内置14.1英寸高亮触摸屏,可外接Titan Fader翼板扩展
20个播放推子,30个自定义宏功能,USB供电)
•支持耳机输出
1个千兆网络接口,支持Art-net、Titan-net、Streaming CAN协议
兼容其他TITAN系统控制台演出文件
•纸箱尺寸:59*54*29 纸箱重量:13.3KG
•航空箱尺寸:59*54*35.5 航空箱重量:22.8Kg"

KL-DC1024

DMX1024 灯光控台

DMX1024 Lighting Console



Technical Specifications

DMX512/1990 standard, maximum 1024 DMX control channels, 2 photoelectric isolation signal outputs. Maximum control of 96 scanners or 96-channel dimming. Use the pearl lamp library (R20 format lamp library), and the lamp library can be written on the console. LCD display with backlight, the first Chinese and English display switchable interface. The panel is available in Chinese and English. Built-in graphic trajectory generator, there are 135 built-in graphics, which is convenient for users to control the graphic trajectory of computer lights, such as circle, spiral, rainbow, chase, and other effects. Graphic parameters (such as amplitude, speed, interval, wave, and direction) can be set independently, making it more convenient and quick to make the desired shape and scene. Each scene can save 5 graphics; at the same time, it can run 10 graphics. Can store 60 materials, Exclusive material It can store 60 replay scenes for storing multi-step scenes and single-step scenes. Each multi-step scene can store up to 600 single steps. 10 replay scenes can be output and run simultaneously. With 10 centralized control putters. Key point control and fader centralized control are compatible. Support functions such as rearrangement of address code, vertical and horizontal exchange, and reverse channel output. Data can be memorized and retained in case of shutdown or sudden power failure. The U disk can back up the console data, and support re-importing to the console for use. The data of the same model console can be shared. Support remote software upgrades and add new functions anytime and anywhere. Preset faders can control the attributes of scanners, attribute control is more convenient and faster. Support blackout immediately

技术参数

DMX512/1990标准,最大1024个DMX控制通道,两路光电隔离信号输出。最多控制96个扫描仪或96通道调光。使用珍珠灯库(R20格式灯库),灯库可以在控制台写入。带背光液晶显示,首创中英文显示可切换界面。该面板有中文和英文版本。内置图形轨迹发生器,内置135个图形,方便用户控制电脑灯的图形轨迹,如圆形、螺旋、彩虹、追逐等效果。图形参数(如振幅、速度、间隔、波浪、方向)可独立设置,更方便快捷地制作出想要的形状和场景。每个场景可保存5张图形;同时可以运行10个图形。可存储60种材料,独家材质可存储60个回放场景,可存储多步场景和单步场景。每个多步场景最多可存储600个单步。可以输出并同时运行10个重播场景。拥有10个集中控制推杆。兼容关键点控制和推子集中控制。支持地址码重排、纵横交换、反向通道输出等功能。关机或突然断电时数据可记忆并保留。U盘可备份控制台数据,并支持重新导入控台使用。同型号主机数据可共享。支持远程软件升级,随时随地的添加新功能。预设推子可以控制灯号的属性,属性控制更方便、快捷。支持立即停电



Technical Specifications

Working voltage: AC110V~240V Frequency: 50/60Hz Features: DMX512 standard, 512 DMX control channels. 2 photoelectric isolation independent output drive ports, with resistance to 1500VDC electrical shock. Independent board structure, easy to replace. Can control 32 sets of 16-channel scanners Large LCD display with backlight for displaying various operating parameters. 16 channel faders, 1 speed control fader. Storage capacity of 1600 chases. 48 chase programs, each program has a maximum of 100 steps. Each step's speed and gradient parameters are set independently. Optional music synchronization or manual speed control. With the cooperation of the chase rate fader, the time range of the program step can be from 0.03s-180s 48 scanner scenes that can be called directly. It can run 4 chase programs and 48 scenes at the same time, and can simultaneously run 32 lanterns manually (lifting lights). The manual operation (lifting lights) has the channel release function. The X/Y of different kinds of scanners are controlled by the data wheel, and can also be controlled by the faders. 16Bit computer light X/Y control accuracy. 15 environment keys to quickly call different scenes, chases, and manual operation combinations. The music trigger signal source can be taken from the audio line input or the built-in microphone pickup. It is easy to learn and use, and the operation efficiency is higher. Shutdown data remains. Built-in high-performance green switching power supply, with extremely low power supply harmonic distortion and extremely wide voltage application range, in line with world power requirements (90V-240V). Size: 56.5 x 40 x 17.5cm Gross weight: 8kg

技术参数

工作电压:AC110V~240V 频率:50/60Hz 特征: DMX512标准,512个DMX控制通道。2个光电隔离独立输出驱动端口,具有抗1500VDC电击能力。独立板卡结构,更换方便。可控制32组16通道扫描仪带背光的大液晶显示屏,可显示各种运行参数。16个通道推子,1个速度控制推子。存储容量1600个程序。48个走灯程序,每个程序最多100步。每一步的速度和梯度参数都是独立设置的。可连音乐同步或手动速度控制。与走灯速率推子配合,程序步的时间范围可从0.03s-180s 48个可直接调用的扫描位场景。可同时运行4个走灯程序。48个场景,可同时手动运行32个灯(升降灯)。手动操作(升降灯)具有通道释放功能。不同型号电脑灯(X/Y)数据控制,也可以由推子控制。16Bit电脑灯X/Y控制精度。15个环境键,快速调用不同场景。走灯、手动操作组合。音乐触发信号源可以取自音频线路输入或内置麦克风拾音。易于易用,操作效率较高。关机数据依然存在。内置高性能绿色开关电源,具有极低的电源谐波失真和极宽的电压应用范围,符合世界电源要求(90V-240V)。尺寸:56.5x40x17.5cm 毛重:8公斤

KL-DC256A

DMX256A 灯光控台

DMX256A Lighting Console



Technical Specifications

DMX512/1990 standard, up to 256 DMX control channels, one optically isolated signal output. Maximum control of 16 computer lights or 64 ways of dimming. Automatically generate light library LCD display with backlight, the first Chinese and English display switchable interface. The panel is available in both Chinese and English. Built-in graphic trajectory generator, with 35 built-in graphics, which is convenient for users to control the graphic trajectory of computer lights, such as drawing circles, spirals, rainbows, chasing, and other effects. Graphic parameters (such as amplitude, speed, interval, wave, and direction) can be set independently, making it more convenient and quick to create the desired shape and scene. Can store 80 playback scenes, used to store multi-step scenes and single-step scenes. Each multi-step scene can store up to 600 single steps. 16 replay scenes can be output and run at the same time. With 16 centralized control faders. Compatible with button point control and fader centralized control. Shutdown or sudden power failure and other data can be stored in memory. The U disk can back up the data of the console and supports reimporting to the console for use, and the data of the same type of console can be shared. Support remote software upgrades, adding new functions anytime and anywhere. The preset fader can control the attributes of computer lights, and the attribute control is more convenient and quick. Support immediate blackout

技术参数

DMX512/1990标准,最多256个DMX控制通道,1路光电隔离信号输出。最大控制16个电脑灯或64种调光方式。自动生成灯库带背光液晶显示,首创中英文显示可切换界面。该面板有中文和英文版本。内置图形轨迹发生器,内置35个图形,方便用户控制电脑灯的图形轨迹,如画圆圈、螺旋、彩虹、追逐等效果。图形参数(如振幅、速度、间隔、波浪、方向)可独立设置,更方便快捷地创建所需的形状和场景。可存储80个回放场景,用于存储多步场景和单步场景。每个多步场景最多可存储600个单步。可以同时输出和运行16个重播场景。具有16个集中控制推子。兼容按键点控制和推子集中控制。关机或突然断电等数据可保存在内存中。U盘可备份控台数据并支持重新导入控台使用,同类型控台数据可共享。支持远程软件升级,随时随地的添加新功能。预设推子可以控制电脑灯的属性,属性控制更加方便快捷。支持立即停电



Technical Specifications

Total number of channels: 240 channels, Number of controllable computer lights: 12 sets The maximum number of channels of Controllable computer lights: 16 channels The maximum number of steps in the program (scene): 40 Steps Total program steps (scenes): 480 Steps Scene pause time: 0.1-25.5 seconds/step Scene transition speed: 0.1-25.5 seconds Dimming channel: 24 channels Display: LCD liquid crystal display, 16*2 characters DMX512 Output interface: 3-core XLR pin seat and socket Storage capacity: 128K large-capacity memory card Input voltage: AC220V-240V, 50/60Hz

技术参数

通道总数:240通道,可控电脑灯数量:12组可控电脑灯最大通道数:16通道程序(场景)最大步数:40步总程序步骤(场景):480个步骤场景暂停时间:0.1-25.5秒/步场景转换速度:0.1-25.5秒调光通道:24通道显示:LCD液晶显示,16*2字符DMX512输出接口:3芯XLR针座及插座存储容量:128K大容量存储卡输入电压:AC220V-240V,50/60Hz

KL-DC240

DMX240 灯光控台

DMX240 Lighting Console

KL-DC192

DMX192 灯光控制台

DMX192 Lighting Console



Technical Specifications

Voltage: AC110/220V
 Frequency: AC 110-220V 50-60Hz
 Power: 8W
 Function: digital display with backlight, 8-channel fader, with page-turning key, control 16 channels, 512 computer lighting console is specially used to control the operation of various computer lights, and adopts dual CPU cooperative processing to realize high-speed processor chip for Precise mathematical operations This machine has extremely convenient and unique editing and operation methods, easy to learn and use, suitable for artistic performances
 Used in theaters, cabaret performances, television broadcasts and other occasions.

技术参数

电压: AC110/220V
 频率: 交流110-220V 50-60Hz
 功率: 8W
 功能: 数字显示带背光, 8通道推子, 带翻页键, 控制16个通道, 512电脑灯光控制台专门用于控制各种电脑灯的运行, 采用双CPU协同处理实现高速处理器芯片用于精确的数学运算本机具有极其方便独特的编辑方式和操作方式, 易学易用, 适合艺术表演用于剧院、歌舞表演、电视转播等场所。

KL-ZT1204K

12*4KW 电源直通箱

12*4KW Power Switch Box



Technical Specifications

Power supply: three-phase five-wire system AC380V ± 10%, frequency 50Hz ± 5%.
 Rated power: 12 road × 4KW; can be applied to any load.
 Overload and short circuit double protection high breaking air switch.
 A.B.C three-phase working indicator. Two-pin and three-pin universal sockets are provided for convenient use, import terminal input, and single 40A bakelite plug output.
 Dimensions (mm): L515 × W485 × H133.
 Weight of single machine: 12 kg.

技术参数

电源: 三相五线制AC380V ± 10%, 频率50Hz ± 5%。
 额定功率: 12路 × 4KW; 可应用于任何负载。
 过载、短路双重保护高分断空气开关。A.B.C三相工作指示灯。提供二芯、三芯万能插座, 使用方便, 进口端子输入, 单路40A胶木插头输出。
 尺寸(毫米): 长515 × 宽485 × 高133。
 单机重量: 12公斤。

KL-DCS08

DMX 8路信号放大器

DMX 8-Channel Signal Amplifier



Technical Specifications

8-channel DMX signal distributor
 technical parameter:
 8-channel independent amplifier drive output.
 Signal amplification and shaping function to extend the signal transmission distance.
 Enhance the ability of the data bus to access the number of devices. Protect the DMX512 output interface of the lighting console, isolate the fault site, and improve the safe operation reliability of the digital lighting control system.
 Power supply: AC90V-240V 50HZ / 60HZ
 Net weight: 1.85KG
 Gross weight: 2.3KG
 Volume: 19"1U, 530 * 180 * 100mm

技术参数

8路DMX信号分配器
 技术参数:
 8路独立功放驱动输出。
 信号放大和整形功能, 延长信号传输距离。
 增强数据总线访问设备数量的能力。保护灯光控制台的DMX512输出接口, 隔离故障现场, 提高数字灯光控制系统的运行可靠性。
 电源: AC90V-240V 50HZ/60HZ
 净重: 1.85KG
 毛重: 2.3KG
 体积: 19"1U, 530*180*100mm

KL-DCS06R

DMX 6路RDM信号放大器

DMX 6-Channel RDM Signal Amplifier



Technical Specifications

Adopt international DMX512-RDMtwo-way communication protocol; it allows your controller to easily and accessibly read and set the parameters of light over long distances. (For example: Set the light address, read the library parameter, and find light) Also, connect more lights.
 1in 6 out
 Each in-out processing circuit adopts a modular design and the user can willfully match the assembly 3 pins or 5 pins in-out modular according to your needs.
 When the output module is broken because of a strong attack from the external current, then the user can fix it at once. So it has another protection method for live shows.
 Each in-this independent power supply and each modular board is isolated with the independent protection circuit and photoelectric isolation.
 They realized the absolute isolation between the signal and the electricity
 The 3 Pin (XLR-3) or 5 Pin (XLR-5) is more durable with the silver metal
 N.W: 0.86KG 11.5*17CM
 Possesses two-way DMX512-RDM protocol function. Can feedback on the light data to MA and other RDM light controller

技术参数

采用国际DMX512-RDM双向通讯协议; 它使您的控制器能够轻松、方便地读取和设置远距离的光参数。(例如: 设置灯地址、读取库参数、查找灯) 另外, 连接更多的灯。
 1进6出
 各输入输出处理电路均采用模块化设计, 用户可任意搭配组装3针或5针输入输出模块
 根据您的需要。
 当输出模块因外部电流的强烈冲击而损坏时, 用户可以立即修复。所以它还有另一个
 直播节目的保护方法。
 内部各独立电源及各模块板均采用独立保护电路及光电隔离隔离。
 他们实现了信号与电力的绝对隔离
 3针(XLR-3)或5针(XLR-5)采用银色金属, 更耐用
 净重: 0.86KG 11.5*17CM
 具有两路DMX512-RDM协议功能。可以将灯光数据反馈给MA和其他RDM灯光控制器



- **Ultra HD resolution superposition**
High-precision unit screen body structure, to ensure that the screen point without color difference, drawing distance height is consistent, no stitching, integrated surface, look and feel shock.
- **Brand lamp beads, the effect is more stable**
The brand lamp bead, longer life, high continuous brightness, high contrast, good mixing effect, more safe and stable
- **Lower the use of power consumption, environmental protection and energy saving**
The service life of the unit board exceeds 10W hours, actively use resource recycling, low power consumption design
- **High gray scale technology, the picture quality is exquisite and real**
Provide accurate and stable colors in the present, deep black field so that the colorful colors can be present, bring you a luxury visual experience

Product Model	PH 0.93	PH 1.25	PH 1.5	PH 1.875
Pixel Pitch	0.9375	1.25	1.5625	1.875
Pixel Density (Point/m)	1137777	640000	409600	284444
Cabinet size (mm)	600*337.5*36	600*337.5*36	600*337.5*36	600*337.5*36
Cabinet Resolution	600*360	480*270	384*216	320*180
Cabinet Weight	5.3	5.3	5.3	5.3
Maintenance Mode	Front	Front	Front	Front
White Balance Luminance (cd)	≥600	≥600	≥600	≥600
Visual Angle	H160V160°	H160V160°	H150V130°	H150V130°
Contrast	≥5000:1	≥5000:1	≥5000:1	≥5000:1
Max. Power (W/㎡)	≤600	≤600	≤600	≤600
Average Power Consumption (W/m ²)	180	180	180	180
Working Voltage	AC100V-240V	AC100V-240V	AC100V-240V	AC100V-240V
Refresh Frequency (Hz)	≥840	≥840	≥840	≥840
Protection Levels	IP5X	IP5X	IP5X	IP5X
LED Lifecycle (H)	100000	100000	100000	100000
Working Temperature (°C)	-30~60	-30~60	-30~60	-30~60
Working Humidity	10%~80%	10%~80%	10%~80%	10%~80%



- **Ultra HD picture quality, large resolution**
Hd resolution, bright colors, restore the real color, fast response, no flash screen, no delay
- **Seamless stitching, hd visual feast**
High-precision unit screen structure ensures the consistency between the points, presenting seamless brightness and color consistent picture
- **High refresh, high brightness**
The picture is stable and smooth, realistic, the response speed and brightness can be automatically adjusted according to the environment, and it is more convenient to change the advertising content
- **Wide vision, refuse to blur**
Various angles display a uniform picture, clear and natural without color, color is not distorted, bringing extraordinary visual experience

Product Model	PH 1.25	PH 1.5	PH1.66	PH1.86
Pixel Pitch	1.25	1.538	360000	1.86
Pixel Density (Point/m)	640000	422500	409600	288000
Cabinet size (mm)	640*480*65	640*480*65	640*480*65	640*480*65
Cabinet Resolution	512*384	416*312	380*288	344*258
Cabinet Weight	6.5	6.5	6.5	6.5
Maintenance Mode	Front	Front	Front	Front
White Balance Luminance (cd)	≥600	≥600	≥600	≥600
Visual Angle	H160°V160°	H150°V130°	H150°V130°	H150°V130°
Contrast	≥5000:1	≥5000:1	≥5000:1	≥5000:1
Max. Power (W/㎡)	≤700	≤700	≤700	≤700
Average Power Consumption (W/m ²)	180	180	180	180
Working Voltage	AC100V-240V	AC100V-240V	AC100V-240V	AC100V-240V
Refresh Frequency (Hz)	≥840	≥840	≥840	≥840
Protection Levels	IP5X	IP5X	IP5X	IP5X
LED Lifecycle (H)	100000	100000	100000	100000
Working Temperature (°C)	-30~60	-30~60	-30~60	-30~60
Working Humidity	10%~80%	10%~80%	10%~80%	10%~80%



Waterproof
Dust-proof

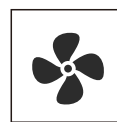

Efficient Heat
Dissipation



Excellent
Energy Saving



Perfect Picture
Quality

GOB display process is a surfacetreatment using nao filling material with optical thermal conductivity feature to finish the lamp board encapsulation and matte finish, not only achieving the great matte visual effect, but also enhancing the LED display protection ability, i.e.great anti-collision feature, dustproof, waterproof, moisture-proof, anti-ultraviolet light, features and it will not have harmful effects on heat dissipation and brightness. The shielding glue even helps on heat dissipation, so as to prolong the LED display service life.

Product Model	Module size (mm)	Module Resolution (Point)	Pixel Density (Point/m ²)	Max. Power (W/m ²)	Average Power (W/m ²)	Luminance (cd)	Visual Angle
GOB1.25	320x160	265x128	640000	≤700	210	≥550	H160°V160°
GOB1.53	320x160	208x104	422500	≤700	210	≥550	H160°V160°
GOB1.66	320x160	192x96	360000	≤700	210	≥550	H160°V160°
GOB1.86	320x160	172x86	288000	≤700	210	≥550	H160°V160°
GOB1.87	240x240	128x128	284000	≤700	210	≥550	H160°V160°
GOB2.0	320x160	160x80	250000	≤700	180	≥550	H160°V160°
GOB2.5	320x160	128x64	160000	≤700	180	≥550	H160°V160°

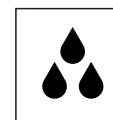

Waterproof
Dustproof

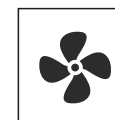

Efficient heat
dissipation



Excellent
Energy
Saving



Perfect
Picture
Quality

- **Low light and high gray, intelligent brightness adjustment**
When the brightness drops to 20%, it still present a perfect picture. Display can automatically adapts to enviroment with the light sensor, output the best picture without influence surrounding lightness.
- **High brightness & wide color gamut, real representation**
The full gamut coverage is over 36%, which is greater than the NESC gamut range
- **Integrated splicing, high precision without stitching**
High-precision unit screen body structure, ensure the screen pixel of same height, no stitching, no color difference, picture integrated; visual Impression

Product Model	Module size (mm)	Module Resolution (Point)	Pixel Density (Point/m)	Max. Power (W/m²)	Average Power (W/m²)	Luminance (cd)	Visual Angle
P2	320x160	160x80	250000	≤600	180	≥600	H150°V130°
P2	256x128	128x64	250000	≤600	180	≥600	H150°V130°
P2.5	160x160	64x64	160000	≤600	180	≥600	H140°V130°
P2.5	320x160	128x64	160000	≤600	180	≥600	H140°V130°
P3	192x192	64x64	111111	≤600	180	≥600	H140°V130°
P4	256x256	64x64	62500	≤600	180	≥600	H140°V130°
P5	320x160	64x32	40000	≤600	180	≥600	H140°V130°



LED flexible display uses flexible FPC circuit board and cover and bottom shell of rubber material, combined with fastener, hinge and so on.

The special designs of above can ensure the flexibility of the LED display, to fulfill the bending forms that other ordinary screens cannot achieve. There are insulating substrate on both side of the panel, where the pixel locates, protecting the circuit from damage. Because of the malleability of the material, the flexible LED display is also known as flexional LED display. It can be made into any shape and size to satisfy the creative design. This is the biggest difference from the traditional flat LED screen. Because of its high elasticity, even been bent into any arc in the installation process, the flexible LED display can still shows a clear and eye-catching image.

Product Model	Module size (mm)	Module Resolution (Point)	Pixel Density (Point/m ²)	Max. Power (W/m ²)	Average Power (W/m ²)	Luminance (cd)	Visual Angle
P1.25	320×160	256×128	640000	≤700	210	≥600	H150°V130°
P1.53	320×160	208×104	422500	≤700	210	≥600	H150°V130°
P1.66	320×160	192×96	360000	≤700	210	≥600	H150°V130°
P1.86	320×160	172×86	288000	≤700	210	≥600	H150°V130°
P2	320×160	160×80	250000	≤600	180	≥600	H150°V130°
P2.5	320×160	128×64	160000	≤600	180	≥600	H140°V130°
P3	192×192	64×64	111111	≤550	160	≥600	H140°V130°
P4	256×128	64×32	62500	≤550	160	≥600	H140°V130°



LED rental display as a customized die-cast aluminum cabinet design, light, thin and fast Installation are its most important feature. The cabinet is thin and light, can be installed, dismantled and transported easily, suitable for large area leasing and fixed installation application. With the usage of the synchronous control system, it is compatible with DVI, VGA, HDM I, S-video, the composite, YUV and other video input signals. It shall output video, graphics and other programs as will, in real-time, synchronous, clear information transmission mode.

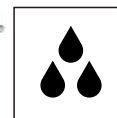

Waterproof
Dust-proof

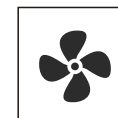

Efficient Heat
Dissipation



Excellent
Energy Saving



Perfect
Picture
Quality

Product Model	PH 1.9	PH 2.6	PH2.9	PH3.9
Pixel Pitch	1.95	2.604	2.9	3.91
Pixel Density (Point/m)	262144	147456	118336	65536
Cabinet size (mm)	500*500*85	500*500*85	500*500/1000*85	500*500/1000*85
Cabinet Resolution	256*256	192*192	172*172/344	128*128/256
Cabinet Weight	6.3	6.3	6.3/11.5	6.3/11.5
Maintenance Mode	Front/Back	Front/Back	Front/Back	Front/Back
White Balance Luminance (cd)	≥800	≥800	≥800	≥800
Visual Angle	H150°V140°	H150°V140°	H150°V140°	H150°V140°
Contrast	≥5000:1	≥5000:1	≥5000:1	≥5000:1
Max. Power (W/㎡)	≤600	≤600	≤600	≤600
Average Power Consumption (W/m ²)	180	180	180	180
Working Voltage	AC100V-240V	AC100V-240V	AC100V-240V	AC100V-240V
Refresh Frequency (Hz)	≥840	≥840	≥840	≥840
Protection Levels	IP54	IP54	IP54	IP54
LED Lifecycle (H)	100000	100000	100000	100000
Working Temperature (°C)	-30~60	-30~60	-30~60	-30~60
Working Humidity	10%~80%	10%~80%	10%~80%	10%~80%



- Exquisite picture quality, shocking visual experience
- High refresh, high gray level, high contrast, and excellent color processing ability
- Present a smooth and delicate picture effect.
- Protection level is up to IP 65, suitable for outdoor usage separately with no cover in extreme weather.



Waterproof
Anti-
Rainstorm

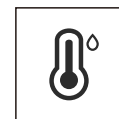

High
Humidity
Resistance

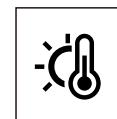

High and low
temperature
resistance



High Anti-
corrosion
Performance

Product Model	SK3	SK5	SK7	SK10
Pixel Pitch	3.91	5.95	7.81	10.4
Pixel Density (Point)/m	65536	28224	16384	9216
Cabinet size (mm)	1000*1000*98	1000*1000*98	1000*1000*98	1000*1000*98
Cabinet Resolution	256*256	168*168	128*128	96*96
Cabinet Weight	30	30	30	30
Maintenance Mode	Front/Back	Front/Back	Front/Back	Front/Back
White Balance Luminance (cd)	≥6000	≥6000	≥6000	≥6000
Visual Angle	H150°V130°	H150°V130°	H150°V130°	H150°V130°
Contrast	≥5000:1	≥5000:1	≥5000:1	≥5000:1
Max. Power (W/㎡)	≤500	≤500	≤500	≤500
Average Power Consumption (W/m ²)	150	150	150	150
Working Voltage	AC100V-240V	AC100V-240V	AC100V-240V	AC100V-240V
Refresh Frequency (Hz)	≥840	≥840	≥840	≥840
Protection Levels	IP66	IP66	IP66	IP66
LED Lifecycle (H)	100000	100000	100000	100000
Working Temperature (°C)	-30~60	-30~60	-30~60	-30~60
Working Humidity	10%~90%	10%~90%	10%~90%	10%~90%



- Exquisite picture quality, shocking visual experience
- High refresh, high gray level, high contrast, and excellent color processing ability
- Present a smooth and delicate picture effect.
- Protection level is up to IP 65, suitable for outdoor usage separately with no cover in extreme weather.



**Waterproof
Anti-
Rainstorm**

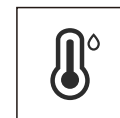

**High
Humidity
Resistance**

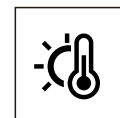

**High and low
temperature
resistance**



**High Anti-
corrosion
Performance**

Product Model	SQ4	SQ5	SQ6	SQ8
Pixel Pitch	4	5.33	6.67	8
Pixel Density (Point/m)	62500	35100	22500	15625
Cabinet size (mm)	960*960*98	960*960*98	960*960*98	960*960*98
Cabinet Resolution	240*240	180*180	144*144	120*120
Cabinet Weight	34	34	34	34
Maintenance Mode	Front/Back	Front/Back	Front/Back	Front/Back
White Balance Luminance (cd)	≥6000	≥6000	≥6000	≥6000
Visual Angle	H150°V130°	H150°V130°	H150°V130°	H150°V130°
Contrast	≥5000:1	≥5000:1	≥5000:1	≥5000:1
Max. Power (W/㎡)	≤500	≤500	≤500	≤500
Average Power Consumption (W/m ²)	150	150	150	150
Working Voltage	AC100V-240V	AC100V-240V	AC100V-240V	AC100V-240V
Refresh Frequency (Hz)	≥840	≥840	≥840	≥840
Protection Levels	IP66	IP66	IP66	IP66
LED Lifecycle (H)	100000	100000	100000	100000
Working Temperature (°C)	-30~60	-30~60	-30~60	-30~60
Working Humidity	10%~90%	10%~90%	10%~90%	10%~90%



- Exquisite picture quality, shocking visual experience
- High refresh, high gray level, high contrast, and excellent color processing ability
- Present a smooth and delicate picture effect.
- Protection level is up to IP 65, suitable for outdoor usage separately with no cover in extreme weather.



Waterproff
Anti-
Rainstorm



High
Humidity
Resistance

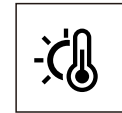

High and low
temperature
resistance



High Anti-
corrosion
Performance

Product Model	MX1.5	MX1.8	MX2	MX2.5
Pixel Pitch	1.5	1.8	2	2.5
Pixel Density (Point)/m	429025	308025	250000	160000
Cabinet size (mm)	600*400*65	600*400*65	600*400*65	600*400*65
Cabinet Resolution	390*260	330*220	300*200	310*160
Cabinet Weight	30	30	30	30
Maintenance Mode	Front/Back	Front/Back	Front/Back	Front/Back
White Balance Luminance (cd)	≥4500	≥4500	≥4500	≥4500
Visual Angle	H150°V130°	H150°V130°	H150°V130°	H150°V130°
Contrast	≥5000:1	≥5000:1	≥5000:1	≥5000:1
Max. Power (W/㎡)	≤500	≤500	≤500	≤500
Average Power Consumption (W/m2)	150	150	150	150
Working Voltage	AC100V-240V	AC100V-240V	AC100V-240V	AC100V-240V
Refresh Frequency (Hz)	≥840	≥840	≥840	≥840
Protection Levels	IP65	IP65	IP65	IP65
LED Lifecycle (H)	100000	100000	100000	100000
Working Temperature (°C)	-30~60	-30~60	-30~60	-30~60
Working Humidity	10%~90%	10%~90%	10%~90%	10%~90%



LED rental display as a customized die-cast aluminum cabinet design, light, thin and fast Installation are its most important feature. The cabinet is thin and light, can be installed, dismantled and transported easily, suitable for large area leasing and fixed installation application. With the usage of the synchronous control system, it is compatible with DVI, VGA, HDMI, S-video, the composite, YUV and other video input signals. It shall output video, graphics and other programs as will, in real-time, synchronous, clear information transmission mode.



**Waterproof
Dust-proof**



**Efficient Heat
Dissipation**



**Excellent
Energy Saving**



**Perfect
Picture
Quality**

Product Model	RG2.9	RG3.9	RG4.8
Pixel Pitch	2.9	3.91	4.81
Pixel Density (Point/m)	118336	65536	43264
Cabinet size (mm)	500*500/1000*85	500*500/1000*85	500*500/1000*85
Cabinet Resolution	172/172/344	128*128/256	104*104/208
Cabinet Weight	6.9/12.6	6.9/12.6	6.9/12.6
Maintenance Mode	Front/Back	Front/Back	Front/Back
White Balance Luminance (cd)	≥4500	≥4500	≥4500
Visual Angle	H150°V140°	H150°V140°	H150°V140°
Contrast	≥5000:1	≥5000:1	≥5000:1
Max. Power (W/㎡)	≤650	≤650	≤650
Average Power Consumption (W/m ²)	195	195	195
Working Voltage	AC100V-240V	AC100V-240V	AC100V-240V
Refresh Frequency (Hz)	≥840	≥840	≥840
Protection Levels	IP65	IP65	IP65
LED Lifecycle (H)	100000	100000	100000
Working Temperature (°C)	-30~60	-30~60	-30~60
Working Humidity	10%~80%	10%~80%	10%~80%

Regular Outdoor Display



**Waterproof
Anti-
Rainstorm**



**High
Humidity
Resistance**

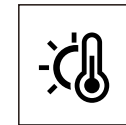

**High and low
temperature
resistance**



**High Anti-
corrosion
Performance**

- Cabinet type: standard /common
- Large screen - flexible and convenient advertising, creative display
- Stable & reliable, excellent display effect
- Protection level is up to IP 65, suitable for outdoor usage separately with no cover in extreme weather

Product Model	Module size (mm)	Module Resolution (Point)	Pixel Density (Point/m ²)	Max. Power (W/m ²)	Average Power (W/m ²)	Cabinet Size (mm)	Luminance (cd)
P2.5	320×160	128×64	160000	≤800	240	960×960	≥4500
P3.07	320×160	104×52	105700	≤750	225	960×960	≥5000
P3	192×192	64×64	111111	≤750	225	960×960	≥5000
P4	320×160	80×40	62500	≤750	225	960×960	≥5500
P4	256×128	64×32	62500	≤750	225	1024×768	≥5500
P5	320×160	64×32	40000	≤700	210	960×960	≥5500
P6	192×192	32×32	27777	≤700	210	960×960	≥6000
P6.6	320×160	48×24	22500	≤700	210	960×960	≥6000
P8	320×160	40×20	15625	≤650	195	960×960	≥6000
P10	320×160	32×20	10000	≤650	195	960×960	≥6000

客户第一、品质卓越, 精诚团结, 求实创新, 以结果为导向。

Customer-Oriented, The Pursuit Of Excellence, Cooperate With Good Faith ,Be Realistic And Innovation, Be Result-Oriented Work.



WhatsApp

产品生产及销售	Product Production And Sales
舞台项目设计	Stage Project Design
灯光秀编程	Light Show Programming
灯光控制台教学	Lighting Console Teaching
舞台项目安装调试	Stage Project Installation And Debugging

www.hello-lite.com

**African Service Center
Binaa Complex, Nairobi ,Kenya**

**China Factory Add
6th Floor, No. 3, Jinhua, Meidong Industrial Park,
No. 22 Tieshanhe Road, Huashan Town, Huadu District, Guzhou City**